

DESIGN AND PERFORMANCE ANALYSIS OF OTA BASED SNR METER

Harish Bhat N.*

Mahaveera K.**

Sathisha***

Abstract—

Signal to Noise Ratio (SNR) measurement plays a crucial role in evaluating the error rate performance of communication systems and to infer whether original message can be extracted from received signal or not. Hence there is a need to measure SNR in an accurate and simple way. The Operational Transconductance Amplifier (OTA) based SNR meter does this task. A noisy signal with additive noise is generated using an OTA based adder which forms the input to the SNR analyser. OTA based band pass filter tuned to signal frequency acquires the signal from the received noisy signal and after subtraction of the acquired signal from the received signal total noise is obtained. The OTA based mean square estimators estimate the mean square values of signal and noise. OTA based logarithmic amplifiers convert mean square values of signal and noise into log of the mean square values. OTA based differential amplifier with a differential gain of 10 with the inputs as log amplifier for signal and noise outputs, produces at the output SNR in dB.

In this paper the OTA based blocks of SNR Meter like Adder, filter, subtractor, mean square estimator, log amplifier and difference amplifier are designed and these blocks are interconnected to design and simulate the SNR Meter. Oscad simulator (an open source alternative to OrCad) is used to simulate the SNR Meter. The present designed SNR Meter estimates SNR in dB within $\pm 10\%$ of the ideal value. Performance analysis is done by comparing the SNR in dB obtained with calculated values.

Index Terms— Band Pass Filter(BPF), Mean Square Estimator Noise (MSEN), Mean Square Estimator Signal(MSES), Operational Transconductance Amplifier (OTA), Signal to Noise Ratio (SNR).

* VIth Sem. M.Tech(Q.I.P.), Dept. Of ECE, NMAMIT Nitte

** Asst. Prof. Dept. of ECE, NMAMIT Nitte,

*** Sr. Asst. Prof. Dept. of ECE, MITE Moodbidri

I. INTRODUCTION

Signal to Noise ratio or SNR as it is known as is an important parameter for analyzing sensitivity performance of any receiver. Hence there is a requirement to measure and analyze SNR of any receiver accurately. Usually the SNR meters measure the SNR in particular band of frequency and also are not accurate because of limited speed of response or bandwidth. Hence there is a requirement to device a SNR meter which can be used for most of the frequency ranges (programmable) and which is also fast to measure the high frequency noise and hence SNR accurately.

The introduced OTA based SNR Meter meets both the requirements of programmability as well as accuracy.

Design Methodology : Purpose of the design is to estimate SNR in dB. SNR in dB is given by,

$$\text{SNR in dB} = 10 * \log \left(\frac{V_{\text{signal}}}{V_{\text{noise}}} \right) \quad (1)$$

Where V_{signal} and V_{noise} are RMS values of signal and noise respectively. When there is a signal with noise whose SNR is to be estimated, initially the signal and noise are to be separated using filters. Mean square values of signal and noise are estimated followed by conversion to logarithm of mean square values. These logarithmic values of mean square values of signal and noise are difference amplified with a gain of 10 to estimate the SNR in dB.

II. ARCHITECTURE OF OTA BASED SNR METER

OTA Based SNR Meter consists of following blocks.

- OTA based Adder
- OTA based Narrow band pass filter
- OTA based subtractor
- OTA based Mean square estimators for signal and noise
- OTA based Logarithmic amplifiers for signal and noise
- OTA based Difference Amplifier.

The inputs and outputs of each of these blocks along with the functions are as given below.

OTA based adder is having inputs as Signal and Noise which are added to produce Signal with additive noise which forms the input to the SNR Meter.

OTA based narrow bandpass filter[4] with a centre frequency equal to that of signal frequency acquires signal from the noisy version of it.

OTA based subtractor[4] with inputs as noisy version of signal and acquired signal from the noisy version, separates noise from the noisy version of Signal.

OTA based mean square estimator[2],[4],[8] for signal is having acquired signal as the input. It estimates the mean square value of the signal. There is a parallel mean square estimator for the noise to estimate the mean square value of noise.

OTA based logarithmic amplifier[3], for signal converts the mean square value into its Logarithm equivalent. There is a parallel Logarithmic amplifier to convert mean square value of noise into its Logarithmic equivalent.

OTA based difference amplifier[4], is having Logarithmic values of mean square values of signal and noise as inputs and it will produce the difference of these two Logarithmic values. The difference is amplified with a gain of 10 to get the SNR in dB.

These blocks are interconnected as shown in figure below.

$V_{CC} = 5V$

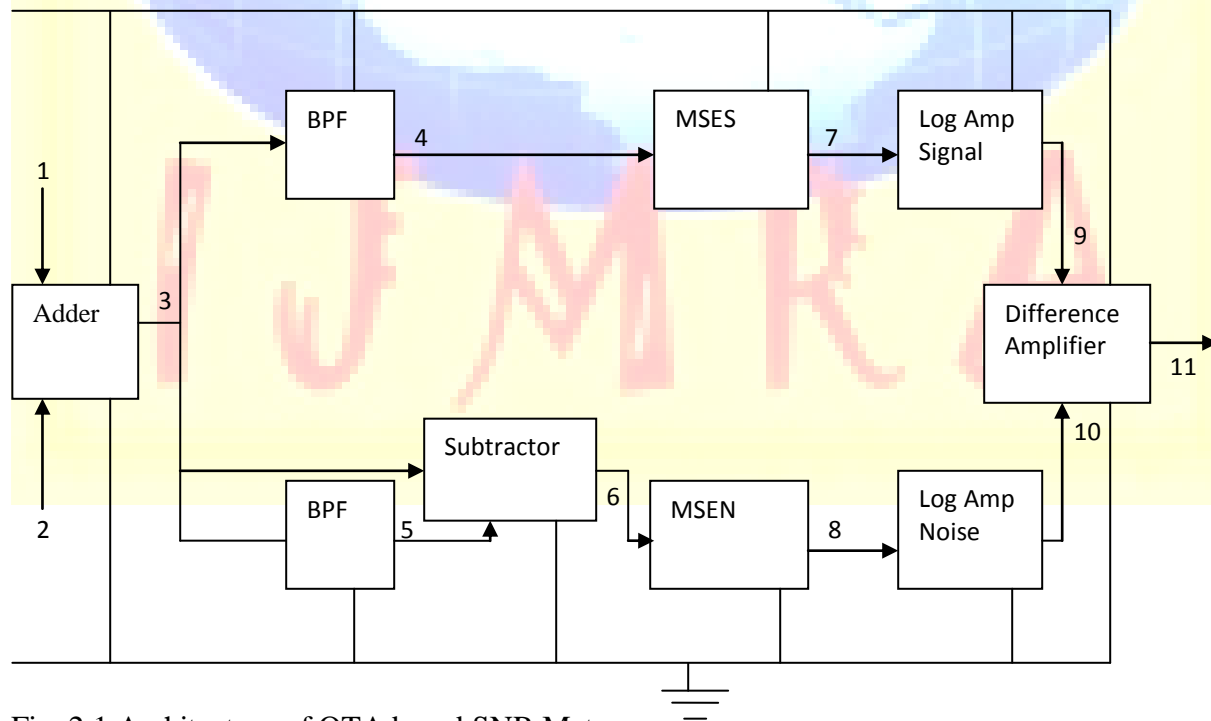

Fig. 2.1 Architecture of OTA based SNR Meter

BPF : Band Pass Filter

MSES: Mean Square Estimator For Signal

MSEN : Mean Square Estimator for Noise

Signal Details At Various Input Output Points Of SNR Meter :

1:Message Signal

2:Noise

3:Signal with Additive Noise

4:Acquired signal from Noisy Version

5:Acquired Signal from Noisy version

6:Acquired Noise

7:Mean Square Value of Signal

8:Mean Square value of Noise

9:Log of Mean square value, Signal

10:Log of Mean square value, Noise

11:SNR in dB

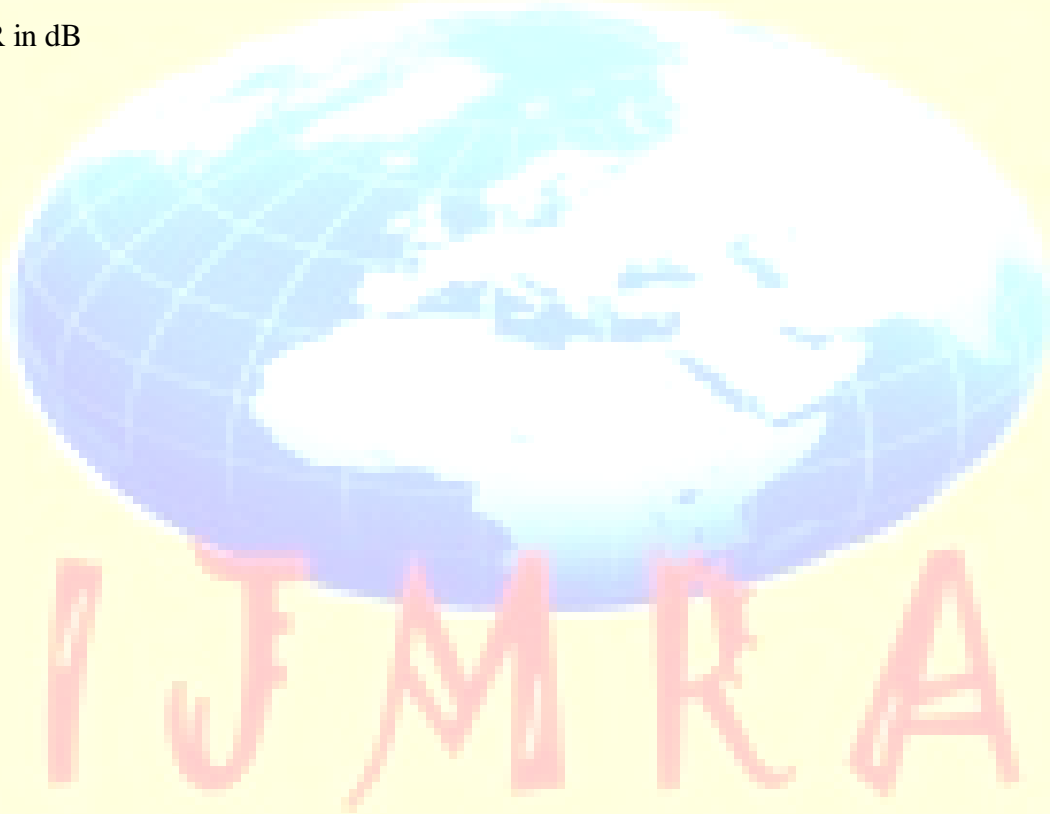

III OPERATIONAL TRANSCONDUCTANCE AMPLIFIER (OTA)

The symbol used for the OTA is shown in Fig. 3.1a, along with the ideal small signal equivalent structure in Fig. 3.1b. The transconductance gain g_m is proportional to the bias current I_{ABC} . The proportionality constant is dependent upon temperature, device geometry and process. Transconductance gain of OTA is given by,

$$g_m = \frac{I_{ABC}}{\eta * V_T} \quad (2)$$

where η is process dependent parameter and V_T is thermal voltage.

$$I_0 = g_m * (V^+ - V^-) \quad (3)$$

where I_0 is the load current, V^+ is the noninverting input and V^- is the inverting input.

As shown in the model the input and output impedances assume the ideal value of infinity. Current and voltage control of gain is possible through I_{ABC} .

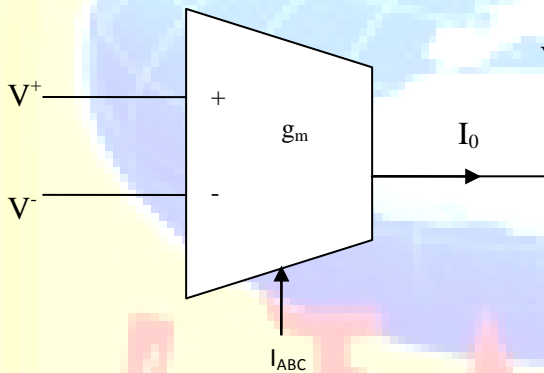

Fig. 3.1a Symbol of OTA

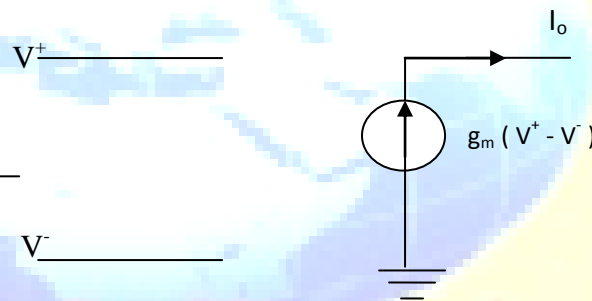

Fig. 3.1b OTA small signal model

Advantages of OTA over Operational Amplifier include better high frequency performance, highly attractive for integration because of low component count, availability of current or voltage control schemes to vary transconductance gain.

The major limitation of OTA's is the restricted input voltage swing required to maintain linearity which is 30 mV peak.

IV DESCRIPTION OF OTA BLOCKS OF SNR METER

Because of attractive design equations, voltage control characteristics, less numbers of components and good high frequency characteristics OTA's are preferred over Op Amps. Hence each of the blocks of SNR Meter are designed based on OTA. Following are the blocks of SNR Meter.

- OTA based Adder
- OTA based Narrow band pass filter
- OTA based subtractor
- OTA based Mean square estimators for signal and noise
- OTA based Logarithmic amplifiers for signal and noise
- OTA based Difference Amplifier.

A. OTA Based Adder: As OTA[9] is a differential amplifier which produces an output, amplified version of the difference of the input. To produce an output of sum of the inputs i.e, to produce $V_a + V_b$, one of the inputs V_b has to be inverted in the first stage to produce $-V_b$ which forms the inverting input to the second OTA and the other input to the second OTA is the input V_a . The output of the second OTA is $V_a + V_b$ i.e, the sum of the inputs. The gain of both the OTA's should be 1, i.e, $g_{m1}R_{L1} = g_{m2}R_{L2} = g_m R_L = 1$ or $R_L = 1/g_m$. For $I_{ABC} = 2\text{mA}$, $g_m = 38.46\text{mA/V}$, Hence $R_L = 26\Omega$. The Adder structure using OTA's is as shown in Fig. 4.1.

The adder of SNR Meter is having the inputs as Signal and Noise to produce noisy version of signal as the output which forms the input to SNR Meter whose SNR is to be estimated.

B. OTA Based 2nd Order Narrow Band Pass Filter : 2nd order OTA based narrow band pass filter[4], structure is as shown in Fig. 4.2. The centre frequency f_0 is given by,

$$f_0 = \frac{g_m}{2 \pi \sqrt{C_1 C_2}} \quad (4)$$

Take $g_m = 38.46 \text{ mA/V}$, and signal frequency $f_0 = 10 \text{ KHz}$ gives $C_1 C_2 = 3.75 * 10^{-13}$.

Hence if $C_1 = 0.62 \mu\text{F}$, then $C_2 = 0.604 \mu\text{F}$.

Here 10 KHz is the frequency of the signal which has to be acquired from noisy version. Hence the adder output when applied to narrow band pass filter acquires the signal from the noisy version.

C.OTA Based Subtractor : As OTA is a difference amplifier it can be used as a subtractor. If we have to use OTA as a subtractor the gain of the OTA based difference amplifier has to be unity. Hence $R_L = 1/ g_m = 26\Omega$. The OTA based subtractor is as shown in Fig. 4.3.

For the subtractor of SNR Meter one of the input should be noisy version of the signal, the other input should be acquired signal which is the output of band pass filter. The subtractor produces noise from the noisy version of signal.

D.Mean Square Estimator: Mean square value MS of a signal V_I is given by,

$$MS = \frac{\int V_I^2 d(\omega t)}{\omega t} \quad (5)$$

Where $\omega = 2\pi f$ is the angular frequency and t is the time. Hence to find mean square value the signal has to be squared, integrated and divided by base. Hence the mean square estimator block diagram is as shown in Fig.4.4. It consists of a OTA based multiplier[2], with both the inputs tied together to produce the square of the signal, an OTA based integrator and a voltage divider. The OTA based squaring circuit ,integrator[4], with voltage divider are as shown in Fig.4.5 and Fig.4.6 respectively.

The output voltage of the squaring circuit is given by,

$$V_o = k_m R_L V_I^2 \quad (6)$$

Where R_L is the load resistance, V_I is the input signal and

$$k_m = \frac{1}{2 R_e V_T} \quad (7)$$

$R_e = (V_{BIAS} / I_{ABC})$ and V_T is the thermal voltage.

For $V_o = V_I^2$, $K_m * R_L = 1$ or $R_L = 1/K_m$.

The output voltage of the integrator is given by,

$$V_o = \frac{g_m}{C} \int V_I d(\omega t) \quad (8)$$

$$\omega = 2\pi f_0 \text{ and } C = \frac{g_m}{2\pi f_0} \quad (9)$$

The voltage divider can be designed as,

$$\frac{R_2}{R_1 + R_2} = \frac{1}{\omega t} \quad (10)$$

There are two mean square estimators in SNR Meter. One for estimating mean square value of signal and the other for that of noise.

E. Logarithmic Amplifier : Logarithmic amplifier using OTA is as shown in Fig. 4.7. There are two Log Amplifiers in SNR Meter. One for signal and the other for Noise. These Log amplifiers convert the mean square values of signal and noise into their Log bases. As shown in the figure it consists of two pnp BJT's working in weak inversion region and an OTA to make the output of log amplifier independent of temperature. The output of the log amplifier is given by

$$V_0 = I_C * R_L * \log\left(\frac{V_{in}}{V_{REF}}\right) \quad (11)$$

For $R_L = 1/I_C$, $V_0 \propto \log(V_{IN})$.

F. Differential Amplifier : The two log amplifiers produce $\text{Log}(V_{\text{signal}})$ and $\text{Log}(V_{\text{noise}})$ which are the inputs to the differential amplifier. It produces the difference of these two. As the differential amplifier is designed for a differential gain of 10 the output signal is $10 * \log\left(\frac{V_{\text{signal}}}{V_{\text{noise}}}\right)$ which is the SNR in dB.

The OTA based structure for differential amplifier is same as that of subtractor as shown in Fig. 4.3 except for the difference in R_L which is $10/g_m$ for the differential amplifier to have a gain of 10.

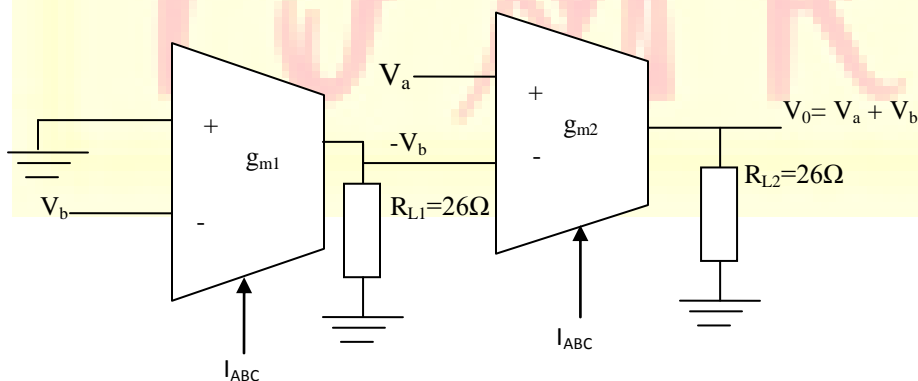

Fig. 4.1 OTA based adder

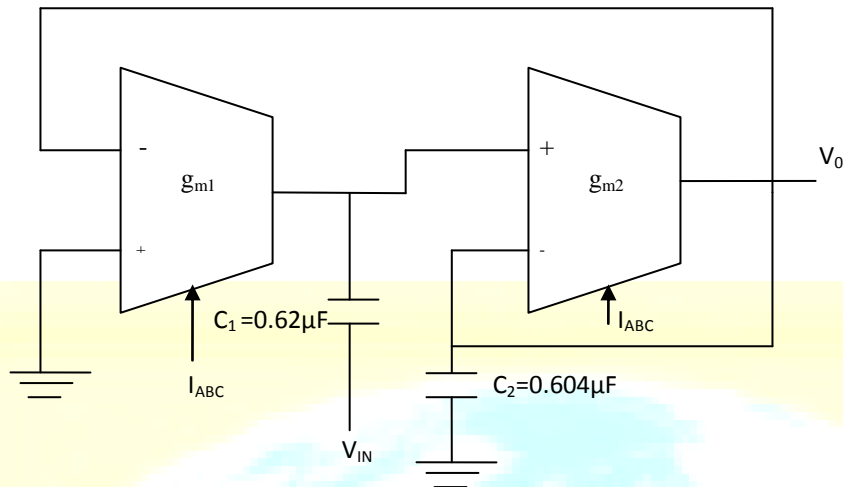

Fig. 4.2 OTA based narrow band pass filter

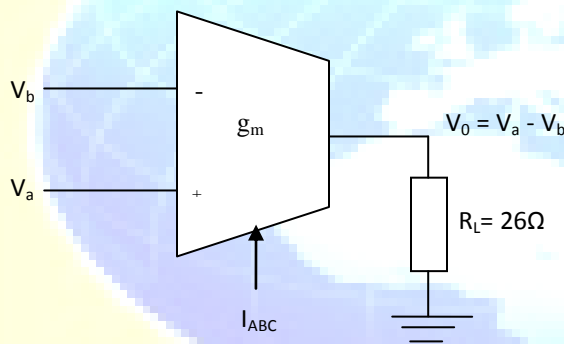

Fig. 4.3 OTA based subtractor

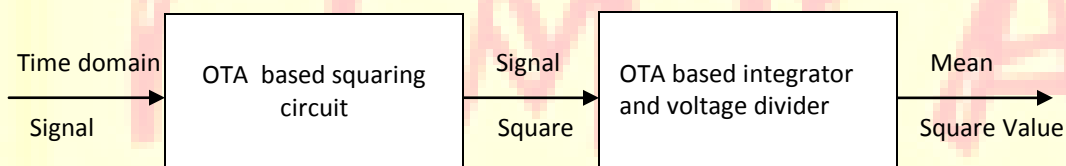

Fig. 4.4 Mean square estimator

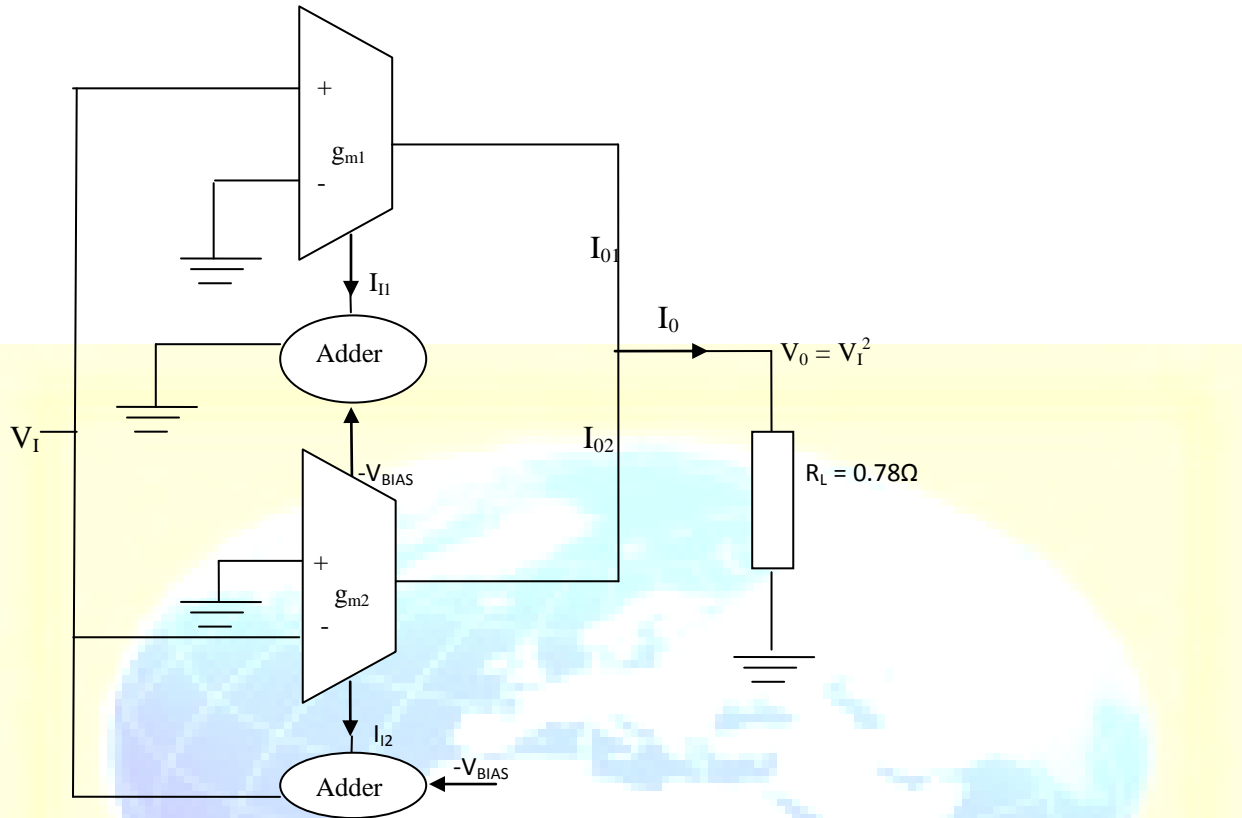

Fig. 4.5 OTA based squaring circuit.

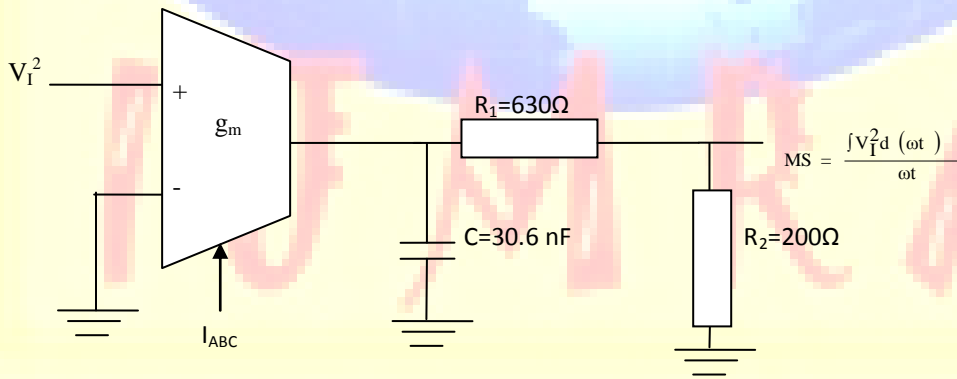

Fig. 4.6 OTA based integrator and voltage divider

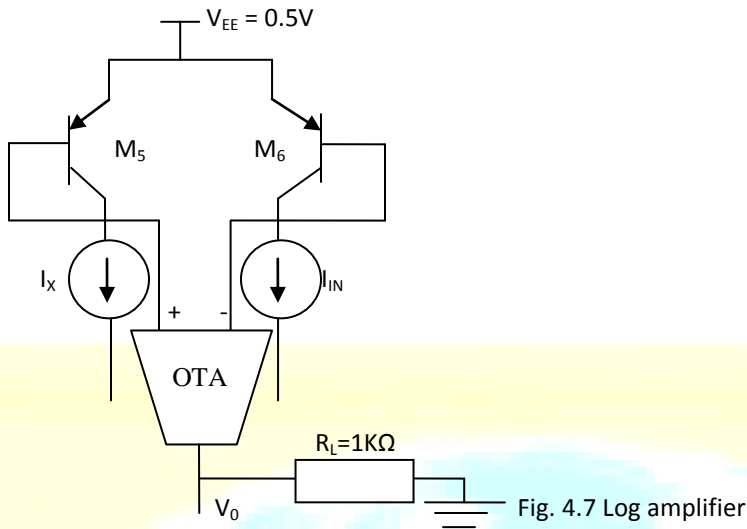

Fig. 4.7 Log amplifier

V SIMULATION RESULTS AND PERFORMANCE ANALYSIS OF SNR METER

The various OTA based blocks of SNR Meter are built as subcircuits[10] using Oscad[10] simulator and are interconnected to create the schematic of SNR Meter. Schematics covered here are OTA based adder (Fig.5.1), OTA based narrow band pass filter (Fig. 5.2), OTA based mean square estimator for signal (Fig. 5.3a and Fig. 5.3b) and OTA based log amplifier for signal (Fig.5.4a and Fig. 5.4b) and the schematic of all the blocks interconnected to get the schematic of SNR Meter (Fig. 5.5).

A. Schematics Of OTA Based SNR Meter:

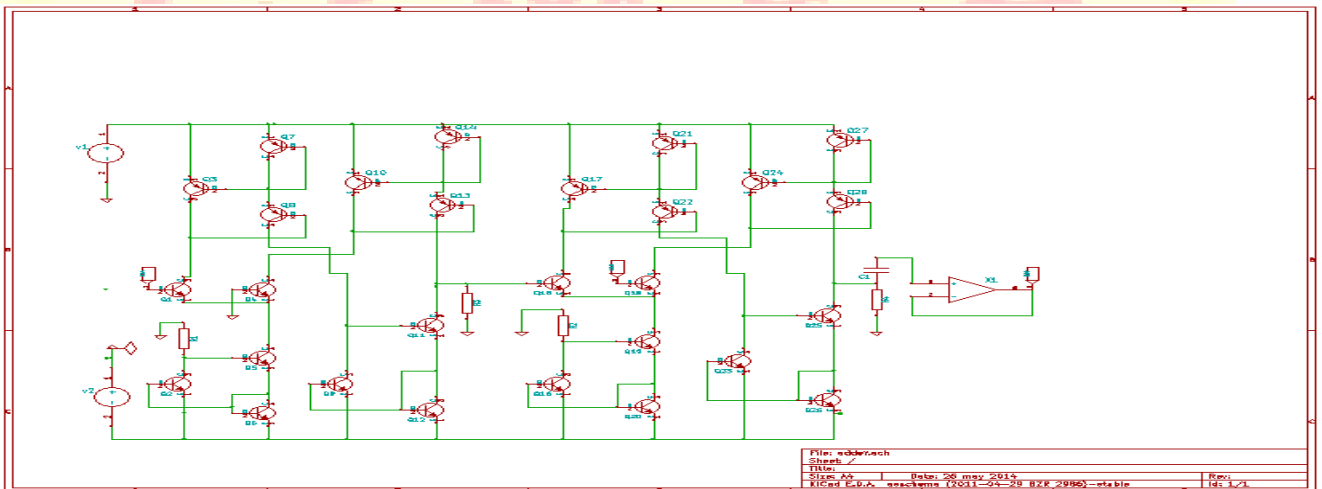

Fig. 5.1 Oscad schematic for the subcircuit OTA based adder

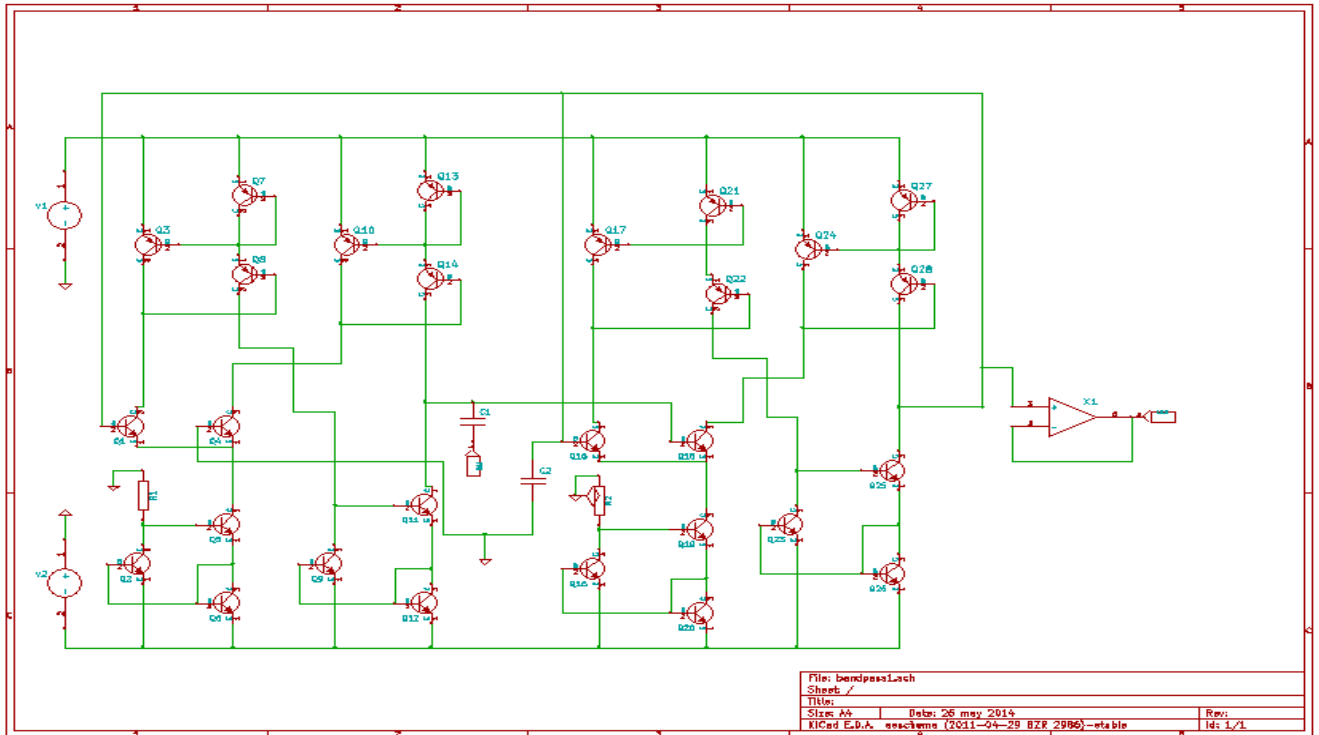

Fig. 5.2 Oscad schematic for the subcircuit OTA based narrow band pass filter

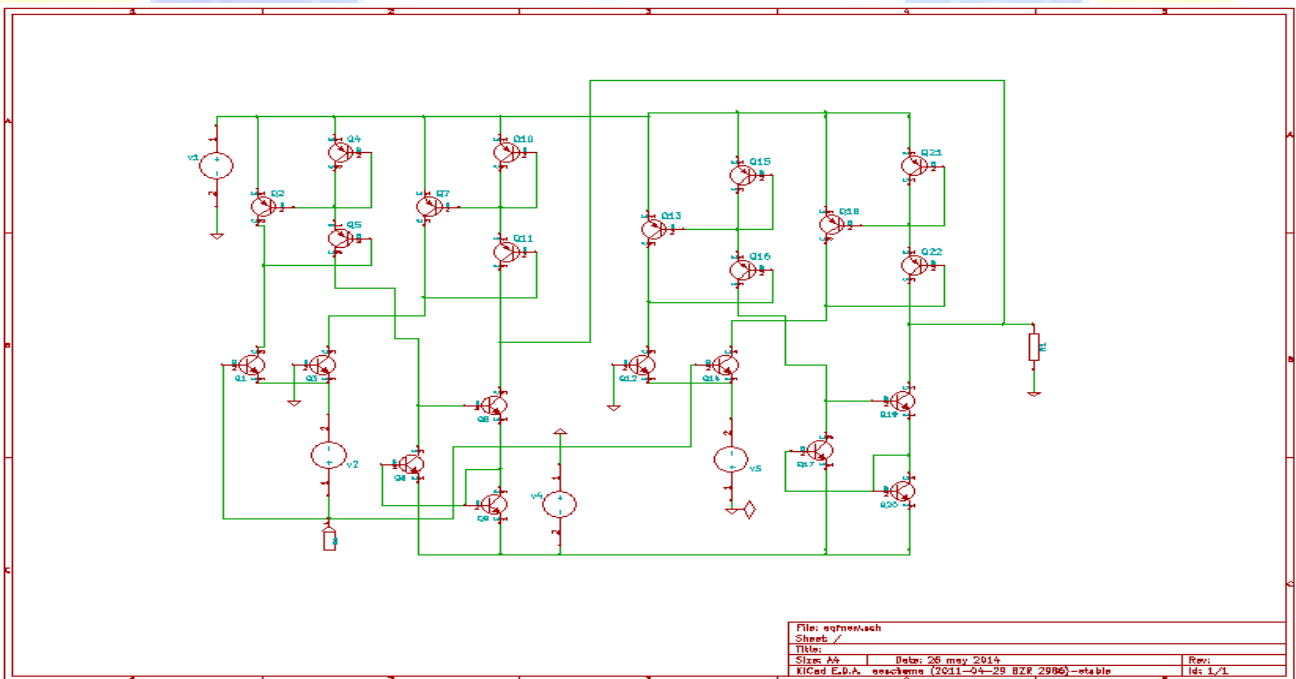

Fig. 5.3a Schematic of the subcircuit OTA based mean square estimator for signal (squaring circuit)

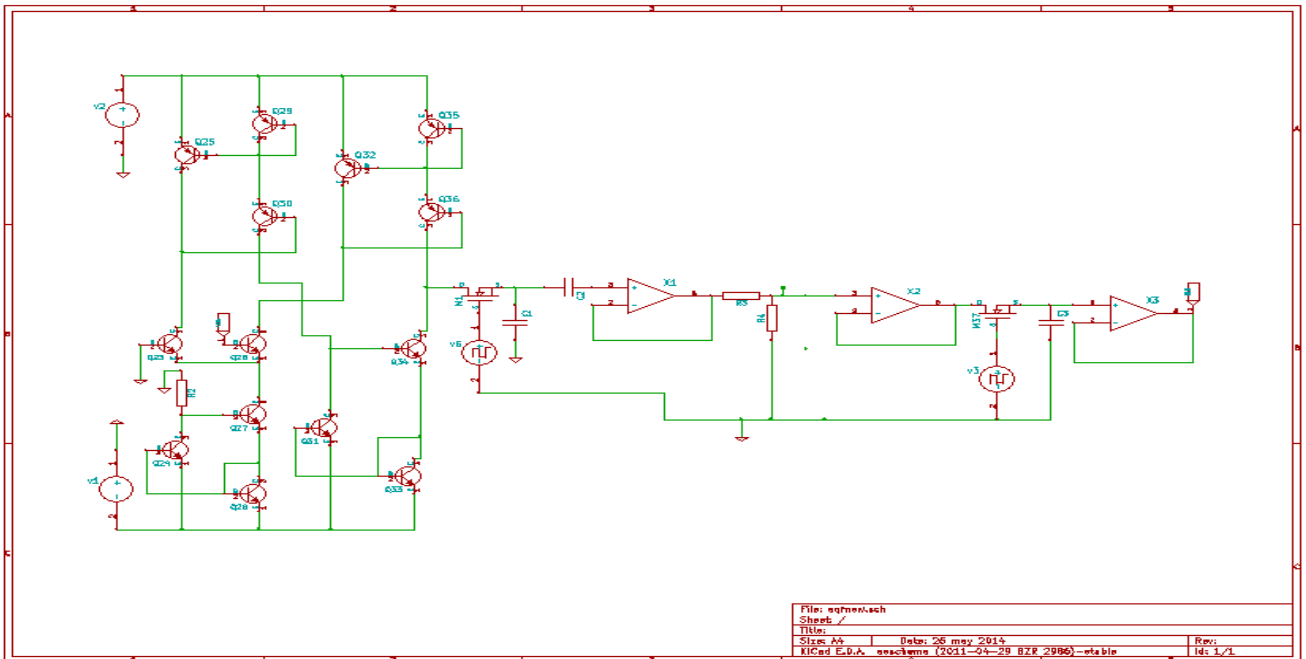

Fig. 5.3b Schematic of the subcircuit mean square estimator for signal (integrator and voltage divider)

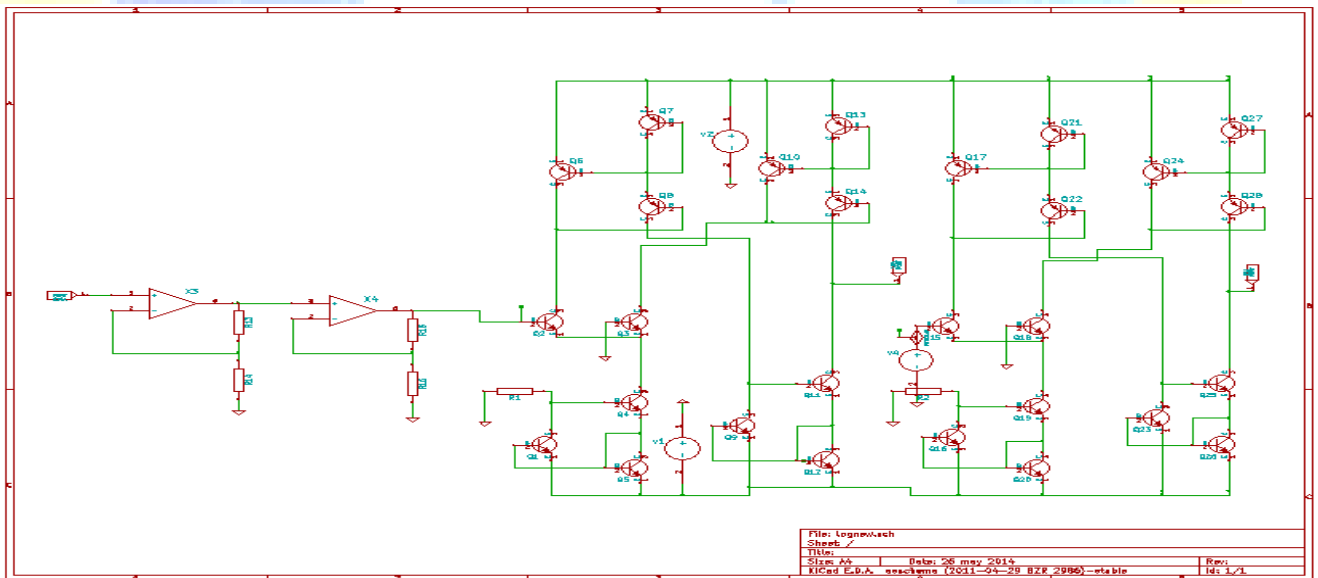

Fig. 5.4a Schematic of the subcircuit OTA based Log amplifier (OTA based V – I converters)

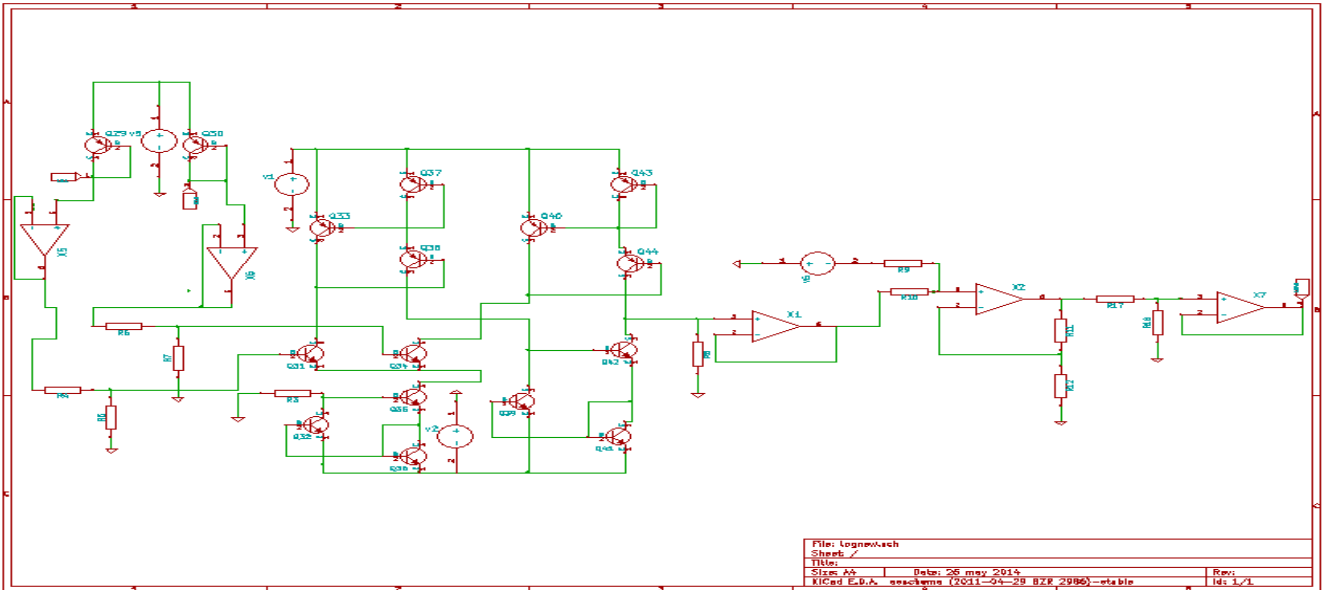

Fig. 5.4b Schematic of the subcircuit Log amplifier for signal (OTA based log amplifier)

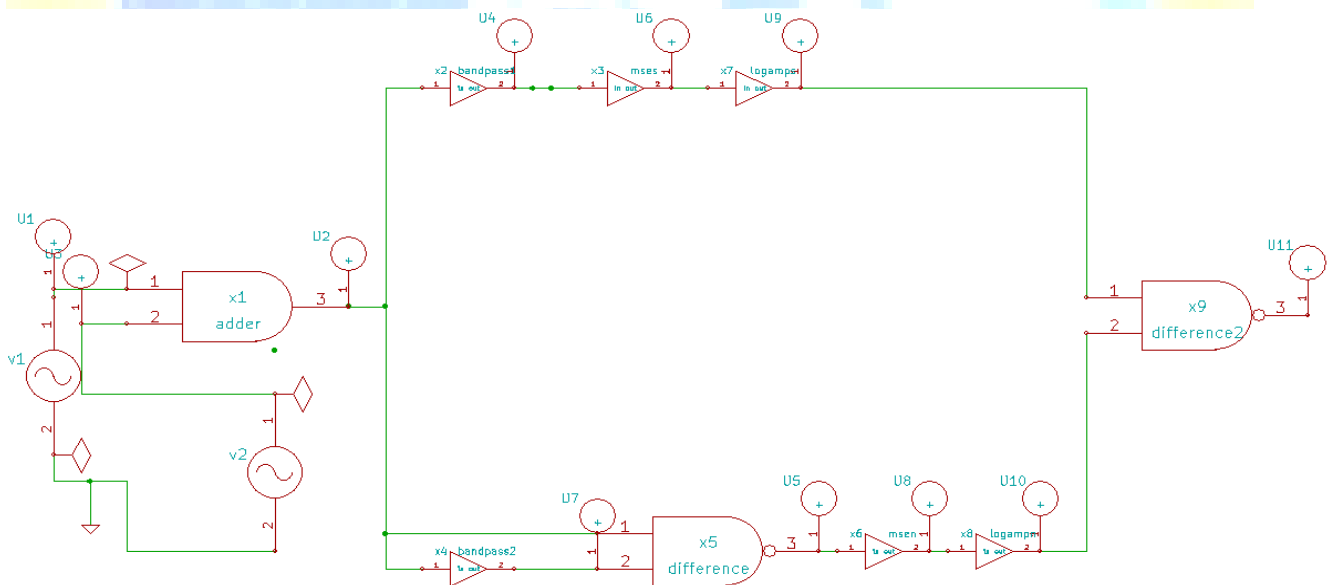

Fig. 5.5 Schematic of the SNR Meter

B. Simulation Results Of Blocks Of SNR Meter: Simulation results of various blocks of SNR Meter for a message signal of 20 mV-P, 10 KHz and noise of 5mV-P, 100 KHz are shown in following Figures. Simulation result of Adder Fig. 5.6, Bandpass filter1 Fig. 5.7, band pass filter2 Fig. 5.8, subtractor Fig. 5.9, mean square estimator for signal Fig. 5.10, mean square estimator for

noise Fig. 5.11, log amplifier for signal Fig. 5.12, log amplifier for noise Fig. 5.13 and differential amplifier Fig. 5.14

The values observed for various blocks of SNR Meter are as follows.

Fig. 5.6 Adder: 23.6066 mV Peak

Fig. 5.7 BPF1: 20.6557 mV Peak

Fig. 5.8 BPF2: 20.4918 mV Peak

Fig. 5.9 Subtractor: 5.12295 mV Peak

Fig. 5.10 MSES: 179.348 μ V

Fig. 5.11 MSEN: 11.9344 μ V

Fig. 5.12 Log amp (Signal): -3.72131V

Fig. 5.13 Log amp(Noise): -4.88356 V

Fig. 5.14 Diff. Amp: 12.5082 V

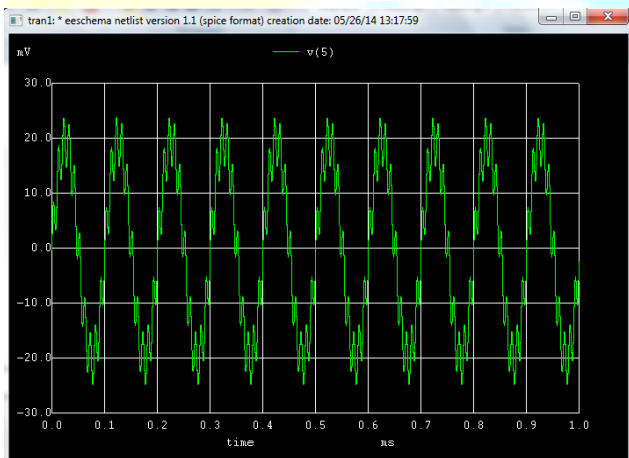

Fig. 5.6 Simulation result for Adder

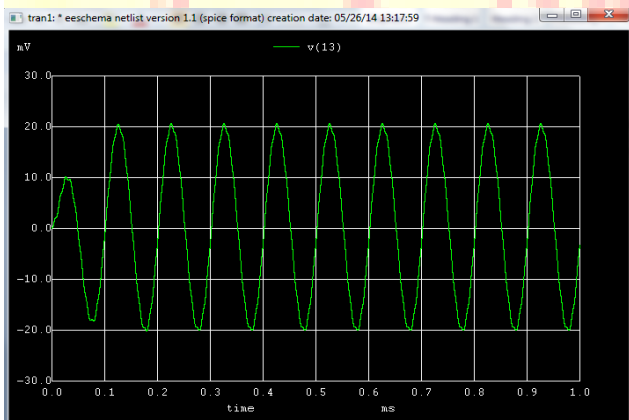

Fig. 5.7 Simulation result for Bandpass filter 1

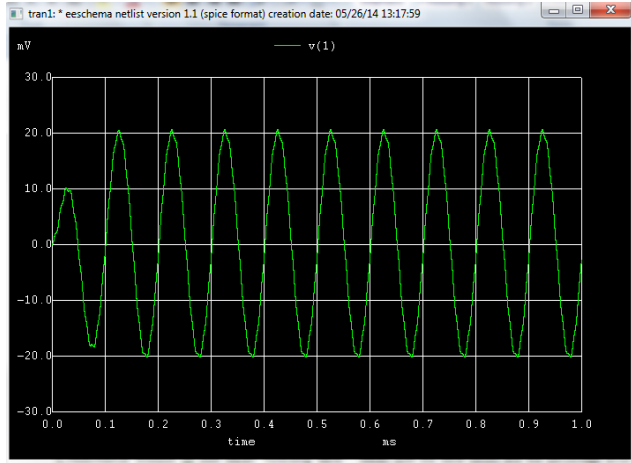

Fig. 5.8 Simulation result for Band pass filter 2

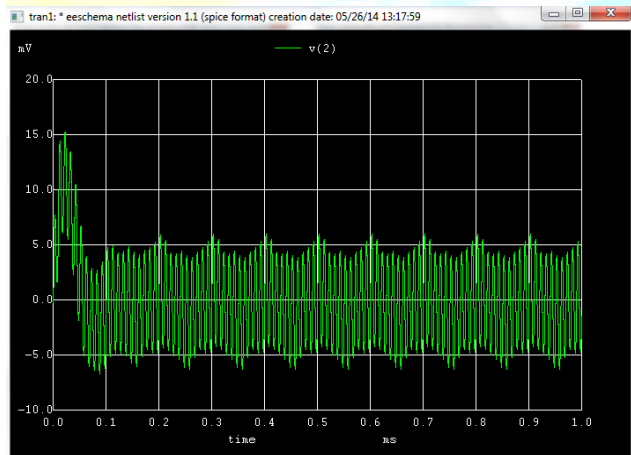

Fig. 5.9 Simulation result for Subtractor

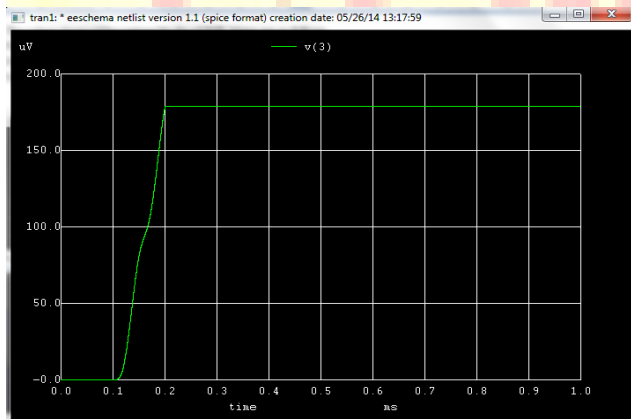

Fig. 5.10 Simulation result for MSES

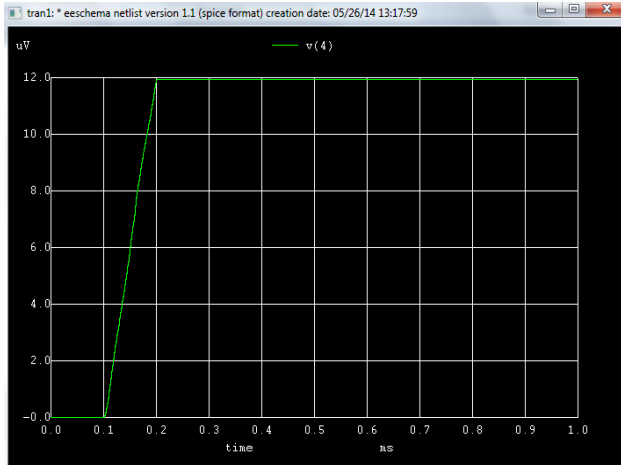

Fig. 5.11 Simulation result for MSEN

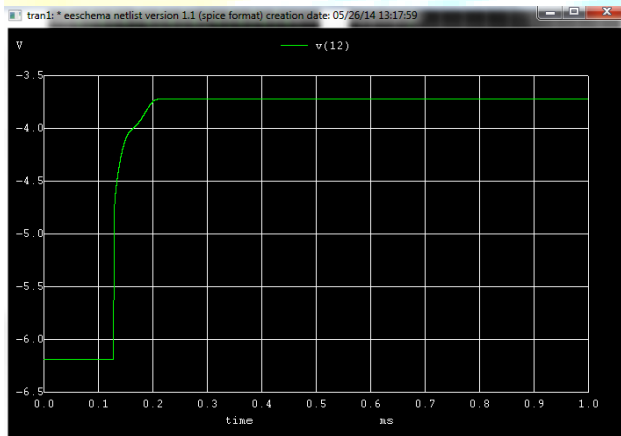

Fig. 5.12 Simulation result, Log amp for signal

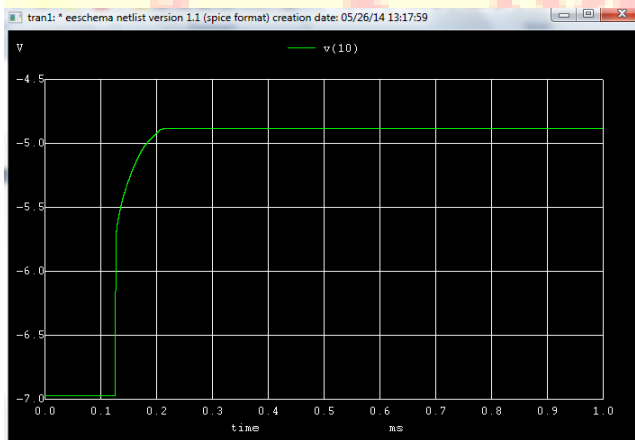

Fig. 5.13 Simulation result, Log amp for noise

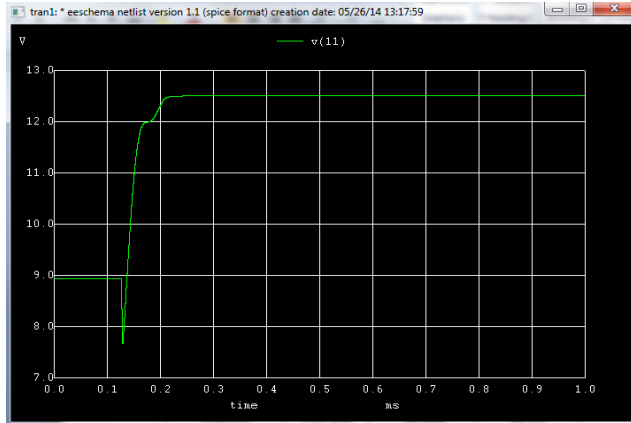

Fig. 5.14 Simulation result for Diff. amplifier

A. Performance Analysis Of SNR Meter: Following table compares the results obtained for various blocks of SNR Meter with the ideal values and the percentage error at each stage.

Table I Performance analysis of SNR Meter

Block	Ideal Value	Simulated Value	Reference Figure	Percentage Error
Adder	25 mV Peak	23.6066 mV Peak	Fig. 5.6	-5.57
BPF 1	20 mV Peak	20.6557 mV Peak	Fig. 5.7	+3.28
BPF 2	20 mV Peak	20.4918 mV Peak	Fig. 5.8	+2.46
Subtractor	5 mV Peak	5.12295 mV Peak	Fig. 5.9	+2.46
MSES	200 μ V	179.348 μ V	Fig. 5.10	-10.33
MSEN	12.5 μ V	11.9344 μ V	Fig. 5.11	-4.52
Log amp for signal	-3.69 V	-3.72131 V	Fig. 5.12	-0.84
Log amp for noise	-4.9 V	-4.88356 V	Fig. 5.13	-0.85
Differential amplifier	12.1 V	12.5082 V	Fig. 5.14	+3.37
SNR	12.1 dB	12.5082 dB	Fig. 5.14	+3.37

As is evidenced in the above table all the blocks and the entire SNR Meter are having acceptable percentage of error.

VI CONCLUSION

Architecture of OTA based SNR Meter is presented. Small signal model of OTA is presented along with design equations. Design of blocks of SNR Meter is presented. The designed blocks of OTA based SNR Meter are simulated using Oscad simulator and simulated results are compared with ideal results.

Advantages of OTA based designs are better high frequency performance, bias current/voltage controlled characteristics, high integrity due to less number of components due to which the SNR meter performed fairly better than the other designs of SNR Meter like Op Amp based.

Limitations of the design are restricted input voltage swing to maintain linearity, High output impedance due to which each blocks have to be interconnected through Op Amp buffers.

ACKNOWLEDGEMENT

The authors wholeheartedly thank **FOSSEE** team at **IIT Bombay** for developing an Open Source, User friendly EDA tool **Oscad** and for all the support they have provided which contributed a lot in completion of this research.

REFERENCES

- [1] David R. Pauluzzi and Norman C. Beaulieu, "A Comparison of SNR Estimation Techniques for the AWGN Channel" IEEE Transactions on Communications Vol 48, No 10, October 2000
- [2] E Sanchez-Senencio and J Ramirez-Angulo, "Operational Transconductance Amplifier – Based Nonlinear Function Syntheses" IEEE Journal of Solid State Circuits, Vol 24, No. 6, December 1989.

- [3] Munir A. Al- Absi and Karama M. Altamimi, “Current mode Controllable Logarithmic Function Circuit using MOSFET in Subthreshold”, Proceedings of the WCECS 2012, Vol 2, San Fransisco, USA.
- [4] R.L. Geiger and E. Sanchez – Senancio, “Active Filter Design Using Operational Transconductance Amplifiers: A Tutorial.” IEEE Circuits and Devices Magazine, Vol. 1, pp 20-32, March 1985
- [5] Adel S. Sedra and Kenneth C. Smith, “Microelectronic Circuits Theory and Applications” Fifth Edition International Version Oxford University Press 2009
- [6] Anil K Maini and Varsha Agarwal, “Electronic Devices and Circuits” First Edition John Wiley and Sons Pte Ltd 2009
- [7] David A. Bell, “Operational Amplifiers and Linear Integrated Circuits” Second Edition Prentice-Hall of India Private Limited.
- [8] M.V.Rao “Basic Electrical Engineering” Lakshmi Mudranalaya Bangalore Edition 2012.
- [9] Sergio Franco “Design With Operational Amplifiers and Analog Integrated Circuits” Third Edition Tata McGraw- Hill Publishing Company Limited 2008
- [10] Yogesh Save, Rakhi R and Shambhulingayya N.D., “OSCAD An Open source EDA Tool for Circuit Design, Simulation analysis and PCB Design” Shroff Publishers June 2013