

RENEWABLE ENERGY SOURCE BASED DC LINK VSI FOR POWER QUALITY IMPROVEMENT USING DSTATCOM

Rajesh*

Sunitha.N.S*

Abstract-

In this paper DSTATCOM (Distribution Static Compensator) is used to supply the required compensating source current which is one of the power quality issue. The reference current methodology applied here is Instantaneous Symmetrical Component Theory (ISRF). ISRF is proposed for three-phase four-wire which includes voltage source converter and a dc link capacitor. The Source power to Voltage Source Inverter (VSI) is performed with constant DC source. The THD is observed in source current. This is compared with wind energy driven VSI. Thus Results are compared for unbalanced and non-linear load. Critical analysis is performed for THD in source current for unbalanced and non-linear load when source for VSI is constant DC supply and wind energy system. It has been observed that the THD in case of wind system is more than constant DC source to VSI. The THD for two phase load is greater than three phase load. THD is compared without and with compensation. All the simulation are carried out in Matlab/simulink based on the optimum method for controlling DC bus of VSI.

Index Terms—Constant DC source, Wind energy driven VSI, Instantaneous Symmetrical Component Theory (ISRF), Total Harmonic Distortion, Neutral Current.

* EEE Dept, Acharya Institute of Technology, Bangalore

I. NOMENCLATURE

ASD - Adjustable Speed Drives
BESS - Battery energy storage system
CPD - Custom Power Devices
DSTATCOM - Distribution Static Compensator
DVR - Dynamic Voltage Restorer
FFT – Fast Fourier Transform
ISRF - Instantaneous Symmetrical Components theory
IGBT - Integrated Gate bipolar Transistor
PCC - Point Of Common Contact
PV - Photovoltaic
PQ - Power Quality
PWM – Pulse Width Modulation
PLC - Programmable Logic Controllers
SPS - Sim Power System
SAF - Shunt Active Filters
SVC – Static Var Compensator
STATCOM – Static Synchronous Compensator
THD – Total Harmonic Distortion
UPQC - Unified Power Quality Conditioner
VSC - Voltage Source Converter

II. INTRODUCTION

Power Quality (PQ) related issues are of most concern nowadays. The widespread use of electronic equipment such as information technology equipment, power electronics such as Adjustable Speed Drives (ASD), Programmable Logic Controllers (PLC), energy-efficient lighting led to a complete change of electric loads nature. These loads are simultaneously the major causers and the major victims of power quality problems [1]. Due to their non-linearity, all these loads cause disturbances in the voltage waveform. with advance in technology, the

organization of the worldwide economy has evolved towards globalization and the profit margins of many activities tend to decrease. The increased sensitivity of the vast majority of processes (industrial, services and even residential) to PQ problems turns the availability of electric power with quality as a crucial factor for competitiveness in every activity sector. The most critical areas are the continuous process industry and the information technology services. When a disturbance occurs, huge financial losses may happen with the consequent loss of productivity and competitiveness [2]. Although many efforts have been taken by utilities, some consumers require a level of PQ higher than the level provided by modern electric networks. This implies that some measures must be taken in order to achieve higher levels of Power Quality.

Power Quality Problems & Issues-A recent survey of Power Quality experts indicates that 50% of all Power Quality problems are related to grounding, ground bonds, and neutral to ground voltages, ground loops, ground current or other ground associated issues. Electrically operated or connected equipment is affected by Power Quality [2,3,4]. Determining the exact problems requires sophisticated electronic test equipment. The following symptoms are indicators of Power Quality problems:

- Piece of equipment misoperates at the same time of day.
- Circuit breakers trip without being overloaded.
- Equipment fails during a thunderstorm.
- Automated systems stop for no apparent reason.
- Electronic systems fail or fail to operate on a frequent basis
- Electronic systems work in one location but not in another location

III. Constant DC supply to VSI

The shunt connected custom power device, called the Distribution Static Compensator (DSTATCOM). This injects the current into the point of coupling. So that harmonic filtering of source current is achieved. The block diagram of test system is as shown in Fig1. The DSTATCOM contains Voltage Source Inverters (VSI) which injects the current at the midpoint through the interface inductor. The operation of VSI depends on the voltage rating

across the de-link capacitor. One important aspect of the compensation is the generation of reference currents. Various control algorithms are available such as synchronous references frame theory, instantaneous PQ theory and instantaneous symmetrical components theory to compute the reference compensator currents. However, due to simplicity in formulation the control algorithm based on Instantaneous Symmetrical Component Theory as shown in Fig.4 is preferred. Based on algorithm, compensator reference currents are as given below:

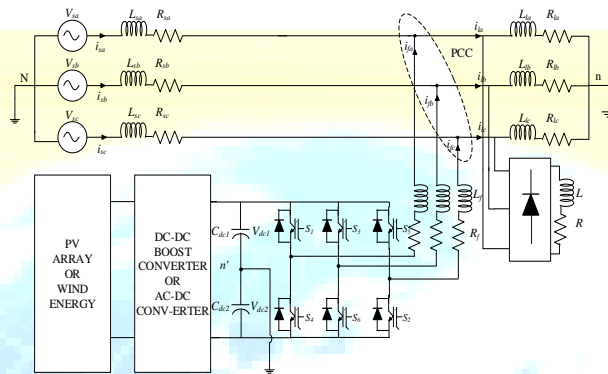

Fig.1 Block Diagram for Test System

$$i_{fa}^* = i_{la} - \frac{v_{sa} + \beta(v_{sb} - v_{sc})}{\sum_{k=a,b,c} v_{sk}^2} (P_{lavg} + P_{loss}) \text{-----(1)}$$

$$i_{fb}^* = i_{lb} - \frac{v_{sb} + \beta(v_{sc} - v_{sa})}{\sum_{k=a,b,c} v_{sk}^2} (P_{lavg} + P_{loss}) \text{-----(2)}$$

$$i_{fc}^* = i_{lc} - \frac{v_{sc} + \beta(v_{sa} - v_{sb})}{\sum_{k=a,b,c} v_{sk}^2} (P_{lavg} + P_{loss}) \text{-----(3)}$$

Where $\beta = \tan \frac{\varphi}{\sqrt{3}}$ and φ is the required phase angle between the voltages and currents in the respective phases. For unity power factor operation, $\varphi = 0$, thus $\beta = 0$. The term P_{lavg} is the dc or average value of the load power. The term P_{loss} in the above equations accounts for the losses in the voltage source inverter without any dc loads in its dc link. The feedback should be able to correct the deviation of the average value of (Vdc) from a reference value (Vrer). There are PQ issues, such as unbalance, deprived power factor, and harmonics produced by telecom equipment in power distribution networks as reported[5]. Therefore, the functionalities of the traditional DSTATCOM should be increased in order to lessen PQ problems and to give away the de loads from its DC link capacitor as well. There are two important issues raised while using the DSTATCOM in the distribution network. The first one is the statute of dc link voltage within the limits under transitory load conditions and the next one is the settling time of the de link voltage controller.

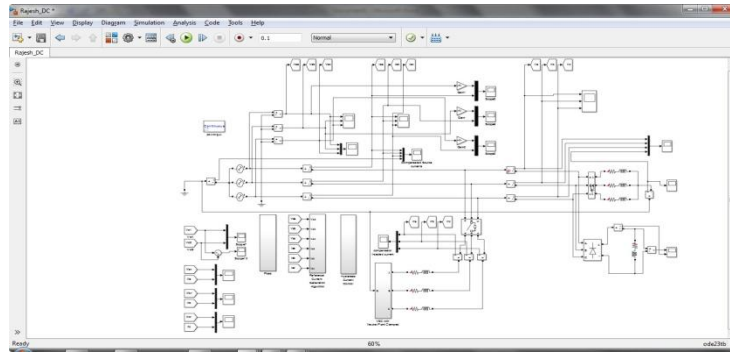

Fig.2 Matlab model for DC voltage driven voltage source converter

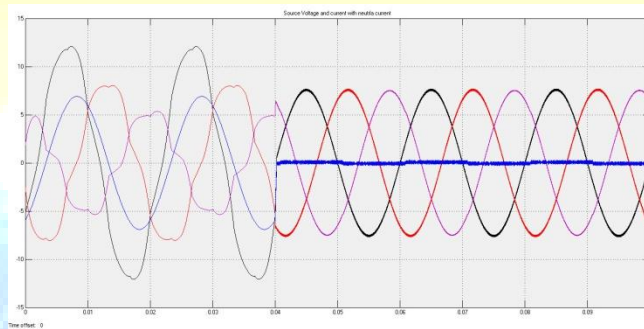

Fig.3 Source current before and after compensation for three phase load and Neutral current.

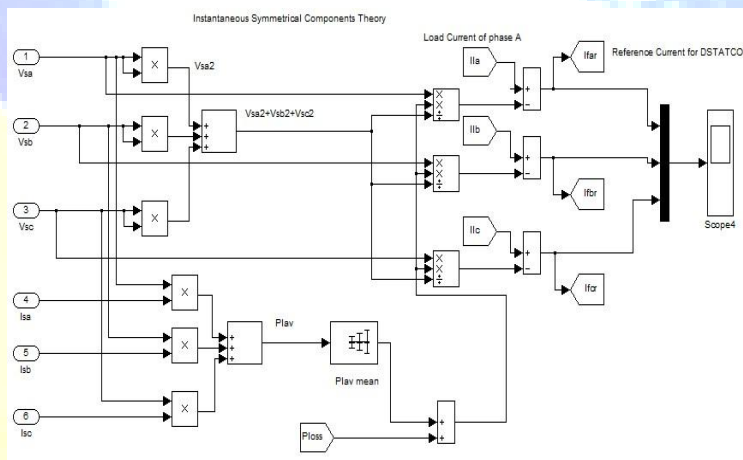

Fig.4 Matlab model for ISRF

Hysteresis Current Controller:

There are various current control methods proposed. Among all the proposed methods, the hysteresis band current control technique has proven to be most suitable for all the applications due to its unconditioned stability, fast response, good accuracy and easy implementation with minimum hardware as shown in Fig.5 for Phase A only. For other phases refer appendix...

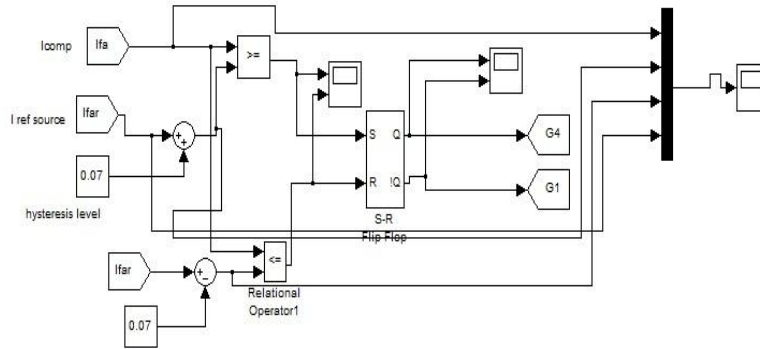

Fig.5 Matlab model for Hysteresis Current Controller for Phase A VSI

The objective of standard two-level hysteresis current regulated control is to switch the inverter transistors in a particular phase so that the current in that phase tracks a reference current within a specified tolerance or hysteresis level. If the phase current becomes greater than the reference current by an amount equal to the hysteresis level ‘*h*’, the phase voltage is switched to its lowest level in order to decrease the current. Likewise, if the phase current becomes less than the reference current by ‘*h*’, the phase voltage is switched to its highest level in order to increase the current. A 3-phase system can also be simply implemented using three independent single-phase hysteresis current regulators. Inverter switched output voltage Conventional two-level hysteresis current regulation As only two dc voltage levels are available, two-level hysteresis current regulation is relatively straightforward with each hysteresis boundary being mapped essentially to one inverter phase leg switched state. In spite of several advantages, the basic hysteresis skills exhibit numerous undesirable features, such as uneven switching frequency that causes acoustic noise and difficulty in designing input filters. The hysteresis band current controller is composed of a hysteresis around the reference line current. the reference line current is referred to as *i_{ref}*, and measured line current is referred to as *i*. The difference between *i* and *i_{ref}* is referred to as δ [6,7].

$$\delta = i - i_{ref}$$

The switching logic is formulated as follows:

If $\delta > HB$ upper switch is OFF ($S1=0$) and lower switch is ON ($S4=1$).

If $\delta < -HB$ upper switch is ON ($S1=1$) and lower switch is OFF ($S4=0$).

The switching logic for phase b and phase c is similar as phase a, using corresponding reference and measured currents and hysteresis bandwidth (HB).

VOLTAGE SOURCE

Three Ideal sinusoidal AC Voltage source, with peak voltage of $230(\sqrt{2})V$. Phase A with 0 degree, phase B as -120 degree and phase C as +120 degree. Frequency for each voltage source is set to 50Hz. Fig.6a to b shows the matlab model for Phase A, B and C respectively.

LOAD -UNBALANCED AND NON-LINEAR LOAD

Loads connected to the source are of two types. Unbalance loads and No-linear load. Table.1 shows the details regarding unbalanced load used for simulation. It also shows the Non-linear load value used for analyzing the source harmonics before and after compensation. While simulating, the phase A is disconnected from the unbalanced load and only phase B and C are connected to the source at time 0.04seconds. After time 0.06 seconds, phase A is reconnected to source.

AC Voltage Source (mask) (link)
Ideal sinusoidal AC Voltage source.
Parameters
Peak amplitude (V):
230*sqrt(2)
Phase (deg):
0
Frequency (Hz):
50

Fig.6a

AC Voltage Source (mask) (link)
Ideal sinusoidal AC Voltage source.
Parameters
Peak amplitude (V):
230*sqrt(2)
Phase (deg):
-120
Frequency (Hz):
50

Fig.6b

AC Voltage Source (mask) (link)
Ideal sinusoidal AC Voltage source.
Parameters
Peak amplitude (V):
230*sqrt(2)
Phase (deg):
120
Frequency (Hz):
50

Fig.6c

Table 1: System parameters

Source Voltage	$230\angle 0^{\circ}$
Balanced Linear Load $R_i + jX_i$	$120 + j125.6\Omega$
Unbalanced Linear Load $R_{la} + jX_{la}$	$30 + j22\Omega$ $60 + j31.4\Omega$ $120 + j125.6\Omega$
DC Load, Non-Linear Load $R_{la} + jX_{la}$	$150 + j12.56\Omega$
DSTATCOM when Battery used	$V_c = 2KV,$ $R_f = 0.01\Omega,$ $L_f = 40mH$
DSTATCOM capacitor with neutral point split capacitor.	$K_p = 0.025$ & $K_i = 0.14$
Hysteresis Band	0.07

Measuring Parameters

The objective of this project is to see the Total Harmonics Distortion (THD) of the sending end current when unbalanced and nonlinear loads are connected at the end uses equipment. At first, phase A of unbalanced load is disconnected from the supply at time 0.04 seconds and reconnected at time 0.06 seconds. THD before compensation and adding compensation after time 0.04 seconds are tabulated in Table.2.

Table.2 : THD for Phase A disconnected in Unbalance load.

With constant DC source	With Phase A open in %	
	THD Without DSTATCOM	THD with DSTATCOM
Phase A	34.04	0.07
Phase B	14.43	0.08
Phase C	17.15	0.59

It can be observed form Table 2, the THD while phase A of unbalanced load is disconnected from 0.04 to 0.06 seconds of simulation time. Phase A, THD was 34.04% before compensation. After compensation, for a time period between 0.04 to 0.1 seconds. THD for phase A was 0.07%. For phase B, THD before compensation was 14.43% which is lesser than phase A. After compensation, THD for phase B was 0.08%. For phase C, THD before compensation was 17.45% which is lesser than phase A but more than phase B. After compensation, THD for phase C was 0.59%., which is the lowest amongst the three phases. The waveforms are shown in appendix . In Table.3, it shows the THD for sending end current for unbalanced load and non-linear load.

Table .3: THD for Unbalanced and Non-Linear load

With constant DC source	With All loads closed in %	
	THD without DSTATCOM	THD with DSTATCOM
Phase A	33.82	1.05/0.04
Phase B	14.43	1.05/0.06
Phase C	17.09	0.64/0.54

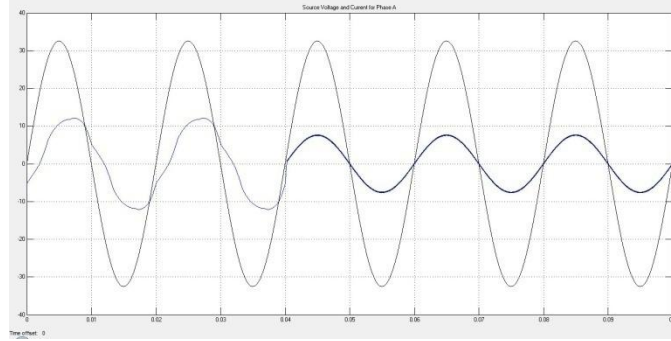

Fig.7 Source Voltage & Current for Two phase load

From Table 3.3, The THD for phase A when both loads are connected at the receiving end is 33.82%. Compensating from 0.06 seconds to the end of simulation time, phase A has 0.4% as its THD. For phase B, THD is 14.43% and after compensation, THD was 0.06%. Phase C has a THD of 17.09 %. After compensation its THD was 0.54%.

It can be observed from Table 3.2 and 3.3 that the THD for phase A sending end current while phase A is disconnected is 34.10 %. When both the loads are connected, THD is 33.98%. It can now be said that the THD is lesser when both loads are connected and it's more when source is connected to two phase load system along with non-linear load. It can also be observed from Fig that, the source current is sinusoidal when phase A is disconnected from the system and reconnected at time 0.06 seconds. Table.4, shows the THD for Neutral current under both cases.

Table.4: THD for Neutral current

With constant DC source	With Phase A open in %		With All loads closed in %	
	THD Without DSTATCOM	THD with DSTATCOM	THD Without DSTATCOM	THD with DSTATCOM
Neutral current	83.59	45.35	83.54	45.57

From Table.4, we can say the neutral current is 83.59% for two phase load without compensation. After compensation, THD is 45.35 %. When unbalanced and non-linear loads are connected to the system, THD without compensation is 83.54 %. THD after compensation is 45.57 %. It can be said here that, THD for two phase load is little greater than, when all the loads are connected the system.

Matlab Model for Wind energy driven DSTATCOM

WIND ENERGY LINKED VSI

The power source to the 3 leg VSI is feed through wind energy. This wind energy is modeled at constant wind speed of 12meter per seconds. The measuring parameters are the THD at sending end for different loading conditions. The controlling parameter for reference current remains same, Instantaneous Symmetrical Component Theory[9]. The objective of standard two-level hysteresis current regulated control is to switch the inverter transistors in a particular phase so that the current in that phase tracks a reference current within a specified tolerance or hysteresis level. The block diagram is shown in Fig 8.

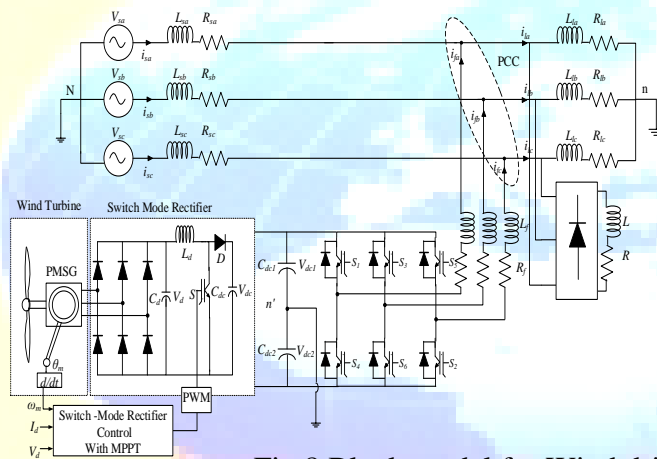

Fig.8 Block model for Wind driven VSI

Voltage Source

The voltage is similar to voltage source used for DC driven DSTATCOM.

Load -Unbalanced & Non-Linear Load

Loads, simulated for comparative analysis for computed THD without compensation and with compensation is same as shown in Table 1 for DC linked VSI.

Measuring Parameters

The objective of this project is to see the Total Harmonics Distortion (THD) of the sending end current when unbalanced and nonlinear loads are connected at the end uses equipment. At first, phase A of unbalanced load is disconnected from the supply at time 0.04 seconds and reconnected at time 0.06 seconds. THD before compensation and adding compensation after time 0.04 seconds are tabulated in Table.8.

Table.5: THD with & without compensation for Wind driven VSC.

With Wind energy	With Phase A open in %	
	THD Without DSTATCOM	THD with DSTATCOM
Phase A	34.04	0.07
Phase B	14.43	0.08
Phase C	17.15	0.59

It can be observed from Table 5, the THD while phase A of unbalanced load is disconnected from 0.04 to 0.06 seconds of simulation time. Phase A THD was 34.04% before compensation. After compensation, for a time period between 0.04 to 0.1 seconds. THD for phase A was 0.07%. For phase B, THD before compensation was 14.43% which is lesser than phase A. After compensation, THD for phase B was 0.08%. For phase C, THD before compensation was 17.15% which is lesser than phase A but more than phase B. After compensation, THD for phase C was 0.59%, which is the lowest amongst the three phases. The waveforms are shown in appendix . In Table 4.2, it shows the THD for sending end current for unbalanced load and non-linear load.

Table.6: THD for both loads

With wind energy	With All loads closed in %	
	THD Without DSTATCOM	THD with DSTATCOM
Phase A	34.27	0.06
Phase B	14.53	0.08
Phase C	17.27	0.59

From Table.6, The THD for phase A when both loads are connected at the receiving end is 34.27%. Compensating from 0.05 seconds, phase A has 0.6% as its THD. For phase B, THD is 14.43% and after compensation, THD was 0.08%. Phase C has a THD of 17.29 %. After compensation its THD was 0.59%.

It can be observed from Table 5 and 6 , that the THD for phase A sending end current while phase A is disconnected is 34.10 % . When both the loads are connected, THD is 34.27%. It can now be said that the THD is lesser when source is connected to two phase load system along with non-linear load and not for all loads connected. It can also be observed form Fig that, the source current is sinusoidal when phase A is disconnected from the system and reconnected at time 0.06 seconds.

Table.7 shows the THD for Neutral current under both loads.

With Wind energy	With Phase A open in %		With All loads closed in %	
	THD Without DSTATCOM	THD with DSTATCOM	THD Without DSTATCOM	THD with DSTATCOM
Neutral current	83.32	45	83.32	45.05

From Table.7, it can be said that the neutral current is 83.51% for two phase load without compensation. After compensation, THD is 45 % . When unbalanced and non-linear loads are connected to the system, THD without compensation is 83.32 % . THD after compensation is 45.05 % . It can be said here that, THD for two phase load is little greater than, when all the loads are connected the system.

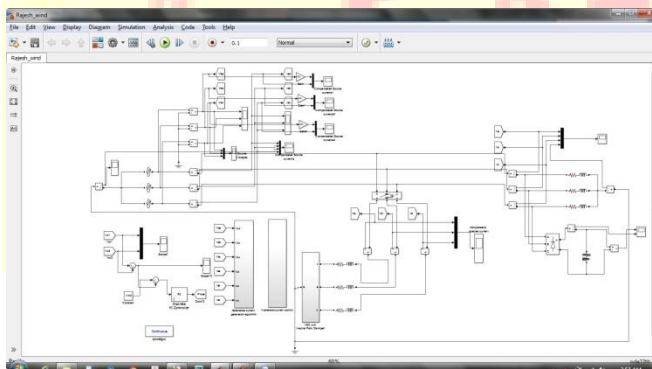

Fig.9. Matlab model for Wind energy voltage driven for voltage source converter

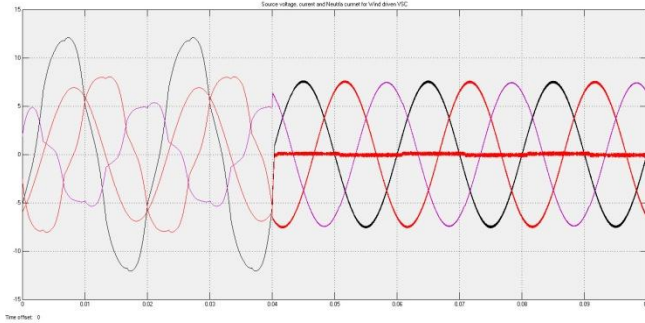

Fig.10. Source currents and Neutral current output waveform

RESULT DISCUSSION

Results are obtained by computing FFT analysis in matlab environment for THD without compensation and with compensation system. Table shows the results for critical review.

Table.8: Comparing THD for two and Three phase load for DC and Wind driven VSI

With constant DC linked VSI	With Phase A open in %		With All loads closed in %	
	THD without DSTATCOM	THD with DSTATCOM	THD Without DSTATCOM	THD with DSTATCOM
Phase A	33.98	0.04	33.98	0.04
Phase B	14.43	0.06	14.43	0.06
Phase C	17.08	0.54	17.09	0.54
Neutral current	83.59	45.35	83.54	45.57
With Wind energy linked VSI	With Phase A open in %		With All loads closed in %	
	THD without DSTATCOM	THD with DSTATCOM	THD without DSTATCOM	THD with DSTATCOM
Phase A	34.04	0.07	34.27	0.06
Phase B	14.43	0.08	14.53	0.08
Phase C	17.15	0.59	17.27	0.59
Neutral current	83.32	45	83.32	45.05

From Table 8, it can be observed that THD for A phase being removed from time 0.04 seconds is less when VSC is using DC voltage. For phase A, THD without compensation for DC linked VSI is 33.98% but in case of wind driven VSC is 34.04. Thus the THD for wind driven DSTATCOM is more than DC driven test system. Fig.11 shows the representation for with and without DSTATCOM for two phase loads. Fig.12 shows the representation for with and without DSTATCOM for three phase load.

With compensation for phase A THD is 33.98 % . For all load, THD is 34.27 % which is greater than DC driven test system. With compensation, the THD for DC driven system is 0.04 % and in case of Wind driven system, its 0.06%.

Thus, for neutral current THD, its 83.59 % and 83.54% for two phase load respected. After compensation, THD is 0.04 % and 0.06% respectively. Thus we can say that the neutral current THD is better than that off DC driven sub.

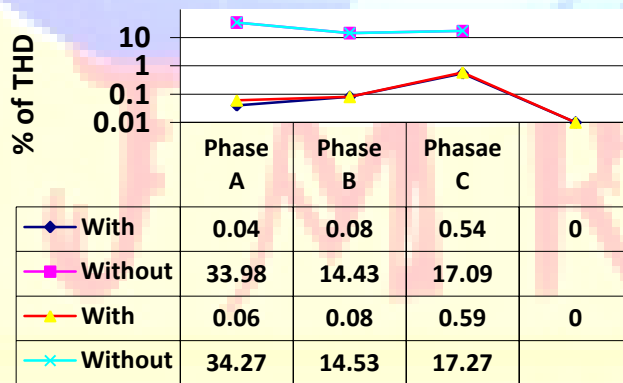

Fig.11 With & without DSTATCOM for Two phase load

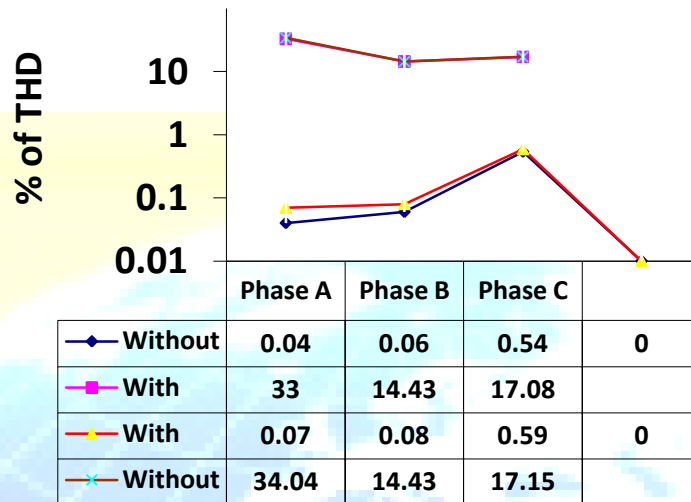

Fig.12 With & without DSTATCOM for Three phase load

CONCLUSION

It is evident now that THD with DSTATCOM is better with constant DC supply. The THD with DC supply to VSI leg, is between 0.04% to 0.54% for two phase load. For three phase load, THD is from 0.04% to 0.54%. With wind energy as the source to VSI leg, the THD is more, 0.07% to 0.59% for two phase load. For three phase load, the THD is from 0.06% to 0.56%. Thus it can be concluded ,THD with ISRF control technique, constant DC supply to VLS leg is better than Wind source to VSI leg.

REFERENCES

- [1] Singh Mukhtiar, Khadkikar Vinod, Chandra Ambrish, Varma and Rajiv K, "Grid Interconnection of renewable energy sources at the distribution level with power quality improvement features," *IEEE Trans Power Deliv*, Vol.26(1), pp.307-315, Jan.2011.
- [2] Pinto JP, Pregitzer R, Monteiro LFC and Afonso JL. "3-Phase 4-wire shunt active filter with renewable energy interface". *Presented at the conference IEEE renewable energy & power quality, Seville, Spain; 2007.*
- [3] Jan T, Bialasiewicz, "Renewable energy systems with photovoltaic powergenerators: operation and modeling," *IEEE Trans Ind Electron*, Vol.55, No.7, pp,2752–2758, July2008.
- [4] Lo Y, Lee T and Wu K, "Grid-connected photovoltaic system with power factor correction," *IEEE Trans IndElectron* , Vol.55, No.5, pp.2224–2227, May2008.
- [5] Dursun Erkan and Kilic Osman, "Comparative evaluation of different power management strategies of a stand-alone PV/Wind/PEMFC hybrid power system," *Int J Electr Power Energy Syst* , Vol.34, No.1, pp-81-89, 2012.
- [6] Wang Yong and Cai Xu, "DC link voltage optimized control for efficient residential fuel cell converter," *Int J Electr Power Energy Syst*, Vol.32, No.9, pp.1031–1036, 2010.
- [7] Changchien SK, Liang TJ, Chen JF and Yang S, "Novel high step-up DC–DC converter for fuel cell energy conversion system," *IEEE Trans Ind Electron* Vol.57, No.6, pp.2007-2017, 2010.
- [8] Suvire Gaston O and Mercado Pedro E, "Improvement of power quality in wind energy applications using a DSTATCOM coupled with a flywheel energy storage system," *Power Electron Conf* , pp.58–64, 2009.

VII. BIOGRAPHIES



Rajesh, received B.E (Electrical) from RGIT, Bangalore in the year 2011 and pursuing M.Tech (Power System Engineering) in Acharya Institute of Technology under Visvesvaraya Technological University, Belgaum. Research interests are Renewable Energy System and FACTS controllers.



Sunitha.N.S, received the B.E (Electrical&Electronics Engineering) and M.Tech (Computer Aided Industrial Drives) degree from Visvesvaraya Technological University in 2005 and 2007 respectively. She is presently working as Asst.Prof. in EEE Dept, Acharya Institute of Technology, Bangalore. She is currently pursuing her Ph.D degree and working on pollution performance of polymeric insulators