

WHEEL CHAIR MOTION CONTROL USING EYE BLINKS

Abhishek Srivastava*

Parnal Patni*

Sandeep Kumar*

Abstract—

In the world today there are millions of people who don't have the capability to move their wheelchairs around by themselves due to paralysis of the body caused by various diseases such as Cerebral Palsy .Cerebral is another word for the brain. Palsy means a complete or partial loss of the ability to move a body part. So cerebral palsy means loss of ability to move a body part because of a problem with the brain. Keeping all this mind we tried to figure out how we can help such people so that they can move by themselves without needing any help and hence we came up with Wheel Chair Motion Control Using Eye Blinks. In this paper, we show how a person has the capability to move the wheelchair with just an eye blink, suppose a person wants to move right in this case he would have to blink his right eye once, in case he wants to move left he blinks the left eye. Similarly if he wants to move straight he will have to blink both the eyes together at a fast rate and in case he wants to stop he blinks the eyes thrice.

* E&TC Department, MITCOE(PUNE), PUNE, INDIA

I. INTRODUCTION

According to New Freedom Initiative Act, there are 100 million disabled and elderly people who are dependent on wheelchair all over the world. A lot of these disabled cannot use the traditional electrical wheelchairs, which are controlled by joystick due to their limb movement restriction. Hence many alternative control methods have been developed to allow those disabled users to live more independently, such as voice recognition and guidance, vision based head gesture etc.

The proposed project controls the wheelchair using Electro-Oculography (EOG) signals. This method allows the user to look around freely while the wheelchair navigates automatically to the desired goal point. The user can even operate the wheelchair using the classic manual method in case the environment and obstacles structure does not help with the auto-navigation method.

In auto-navigation method, the microcontroller determines the goal point direction and distance by calculating the gaze angle that the user is gazing at.

II. ELECTRO-OCCULOGRAPHY (EOG)

The Electro-Oculography (EOG) is a method for sensing eye movement and is based on recording the standing corneal-retinal potential arising from hyper polarizations and depolarization existing between the cornea and the retina; this is commonly known as an electro-oculogram (EOG) Usually, pairs of electrodes are placed either above and below the eye or to the left and right of the eye.

If the eye is moved from the centre position towards one electrode, this electrode sees the positive side of the retina and the opposite electrode sees the negative side of the retina. Consequently, a potential difference occurs between the electrodes. Assuming that the resting potential is constant, the recorded potential is a measure for the eye position

The EOG signals are obtained by placing electrodes 'A' to detect positive voltage and another electrodes 'B' to detect negative voltage. A reference (Ground) electrode 'C' is placed on the side of the eye. Using electrode A and B we get the vertical position of the eye and it detects intentional blink also.

Similarly, A', B' and C' are the position of electrodes for second eye. Simple Ag-AgCl electrodes are generally used in recordings. Due to the low impedance range of the silicon-rubber conducting electrode, it is more suitable to sense the very low amplitude bio- signals.

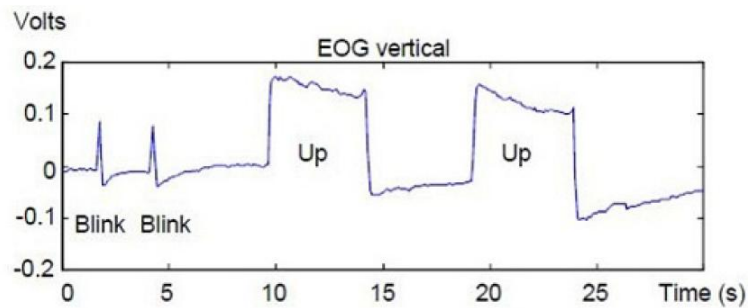

Fig 1: Eye movement and Blink detection (vertical EOG)

the

III . SYSTEM SCHEMATIC AND SPECIFICATIONS

MICROCONTROLLER (ATMEGA 16):

- High-performance, Low-power Atmel® AVR® 8-bit Microcontroller
- Advanced RISC Architecture
 - 131 Powerful Instructions – Most Single-clock Cycle Execution
 - 32 x 8 General Purpose Working Registers
 - Fully Static Operation
 - Up to 16 MIPS Throughput at 16 MHz
 - On-chip 2-cycle Multiplier
- High Endurance Non-volatile Memory segments
 - 16 Kbytes of In-System Self-programmable Flash program memory
 - 512 Bytes EEPROM
 - 1 Kbyte Internal SRAM
 - Write/Erase Cycles: 10,000 Flash/100,000 EEPROM
 - Data retention: 20 years at 85°C/100 years at 25°C
 - Optional Boot Code Section with Independent Lock Bits
 - In-System Programming by On-chip Boot Program True Read-While-Write Operation.
 - Programming Lock for Software Security
- JTAG (IEEE std. 1149.1 Compliant) Interface
 - Boundary-scan Capabilities According to the JTAG Standard

- Extensive On-chip Debug Support
- Programming of Flash, EEPROM, Fuses, and Lock Bits through the JTAG Interface.

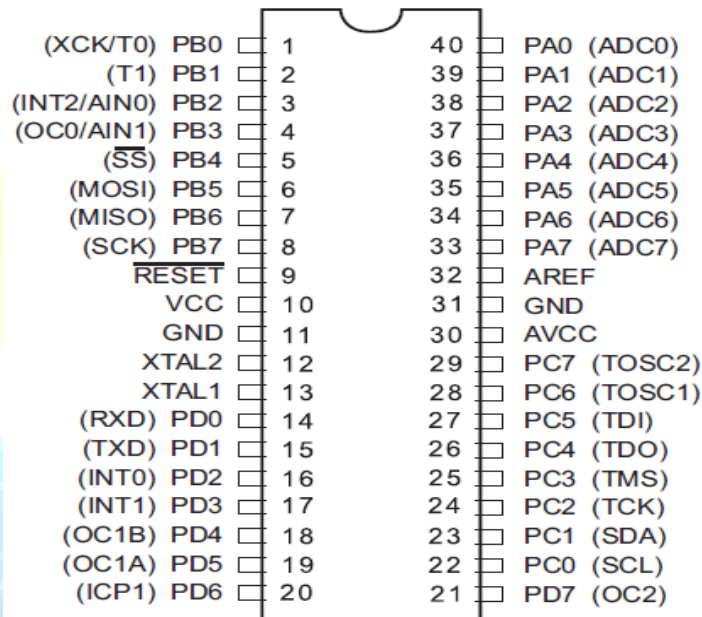

Fig 2. Pin Diagram of microcontroller

- Peripheral Features
 - Two 8-bit Timer/Counters with Separate Pre scalars and Compare Modes
 - One 16-bit Timer/Counter with Separate Pre scalars, Compare Mode, and Capture mode
 - Real Time Counter with Separate Oscillator
 - Four PWM Channels
 - 8-channel, 10-bit ADC
 - 8 Single-ended Channels
 - 7 Differential Channels in TQFP Package Only
 - 2 Differential Channels with Programmable Gain at 1x, 10x, or 200x
 - Byte-oriented Two-wire Serial Interface
 - Programmable Serial USART
 - Master/Slave SPI Serial Interface

- Programmable Watchdog Timer with Separate On-chip Oscillator
- On-chip Analog Comparator
- Special Microcontroller Features
 - Power-on Reset and Programmable Brown-out Detection
 - Internal Calibrated RC Oscillator
 - External and Internal Interrupt Sources
 - Six Sleep Modes: Idle, ADC Noise Reduction, Power-save, Power-down, Standby and Extended Standby
- I/O and Packages
 - 32 Programmable I/O Lines
 - 40-pin PDIP, 44-lead TQFP, and 44-pad QFN/MLF
- Operating Voltages
 - 4.5V - 5.5V
- Speed Grades
 - 0 - 16 MHz

ULTRASONIC SENSOR:

Ultrasonic ranging module HC - SR04 provides 2cm - 400cm non-contact measurement function, the ranging accuracy can reach to 3mm. The modules includes ultrasonic transmitters, receiver and control circuit. The basic principle of work:

- (1) Using IO trigger for at least 10us high level signal,
- (2) The Module automatically sends eight 40 kHz and detect whether there is a pulse signal back.
- (3) IF the signal back, through high level , time of high output IO duration is the time from sending ultrasonic to returning. Test distance = (high level time× velocity of sound (340M/S) / 2,



. Ultrasonic sensor

Wire connecting direct as following:

- ⌘ 5V Supply
- ⌘ Trigger Pulse Input
- ⌘ Echo Pulse Output
- ⌘ 0V Ground

Electric Parameter:

Working Voltage	DC 5 V
Working Current	15mA
Working Frequency	40Hz
Max Range	4m
Min Range	2cm
Measuring Angle	15 degree
Trigger Input Signal	10uS TTL pulse
Echo Output Signal	Input TTL lever signal and the range in proportion
Dimension	45*20*15mm

Table 1

MOTOR DRIVER:

- Featuring Unitrode L293 and L293D
- Products Now From Texas Instruments
- Wide Supply-Voltage Range: 4.5 V to 36 V
- Separate Input-Logic Supply
- Internal ESD Protection
- Thermal Shutdown
- High-Noise-Immunity Inputs
- Functional Replacements for SGS L293 and SGS L293D
- Output Current 1 A Per Channel (600 mA for L293D)
- Peak Output Current 2 A Per Channel (1.2 A for L293D)
- Output Clamp Diodes for Inductive
- Transient Suppression (L293D)

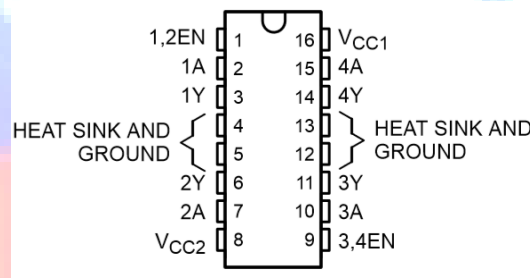

Fig 3. Pin diagram of L293D

MUSCLE SENSOR:

- Small Form Factor (1inch X 1inch)
- Specially Designed For Microcontrollers
- Adjustable Gain –Improved Ruggedness
- New On-board 3.5mm Cable Port
- Pins Fit Easily on Standard Breadboards



Muscle Sensor kit

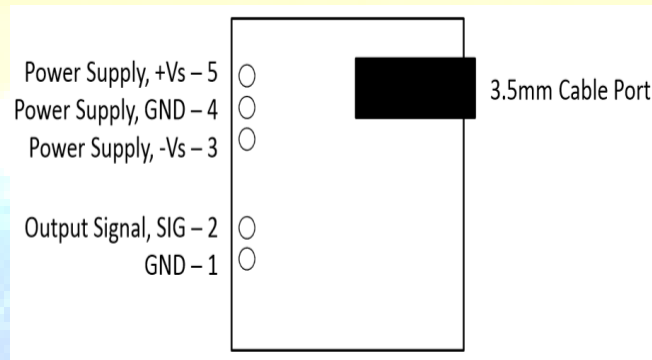

Fig 4. Pin diagram of Muscle sensor

IV . BLOCK DIAGRAM

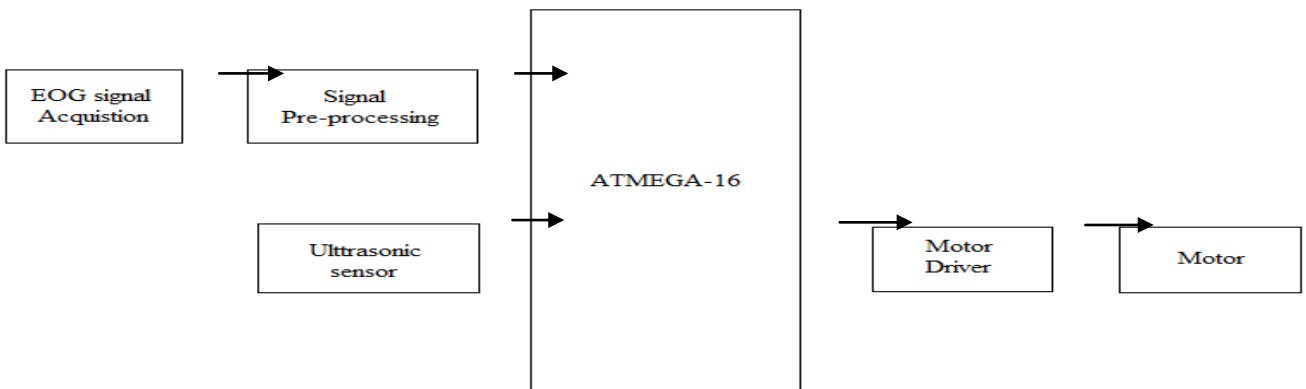

Fig 5

EOG signal is obtained by using biopotential electrodes i.e Ag\ AgCl electrodes which measures the potential of the skin surface. EOG signal are relatively low level signals having a range of 6 μ V to 1mV.Hence, output of electrodes is given to the amplifier for initial amplification. Amplifier (AD620) also reduces the noise of the signal.

Obtained signal should be converted into digital by ADC. So the output of amplifier is given to the microcontroller. After receiving amplified signal microcontroller determines whether the wheelchair needs to move right, left or straight.

A ultrasonic sensor is used to find free space in any direction.

Then controls signals are provided by the microcontroller to the motor. Control signals provided by the microcontroller are responsible for the functioning of wheel-chair.

V. ALGORITHM

- 1) Ultrasonic sensor value should be greater than a predefined threshold. Threshold is basically the distance at which the wheelchair should stop if it detects blocking of the path.
- 2) Now read the left sensor value and then the right sensor value or vice versa.
- 3) When the threshold is equal to zero then repeat the same as above.
- 4) If the value of threshold is greater than zero then in that case we put the value of the left sensor in left threshold similarly for the right sensor we put the detected value in the right threshold.
- 5) Now we know both the values so we set a range for both the thresholds. For setting a range what we do is select a value say 10 for ex and t is our threshold value so if the sensor detected value is more or less that (t+10) or (t-10) then there is movement of the wheel chair.
- 7) The range for the left side and the right side can be different.
- 6) There are three cases to be considered:

- i) Forward movement-if both the values of the right and left eye is more or less than the threshold range then there is forward movement.
- ii) Left movement-if only the left eye sensor value crosses the range then there is left movement only
- iii) Right movement-if only the right eye sensor value crosses the range then there is right movement only.

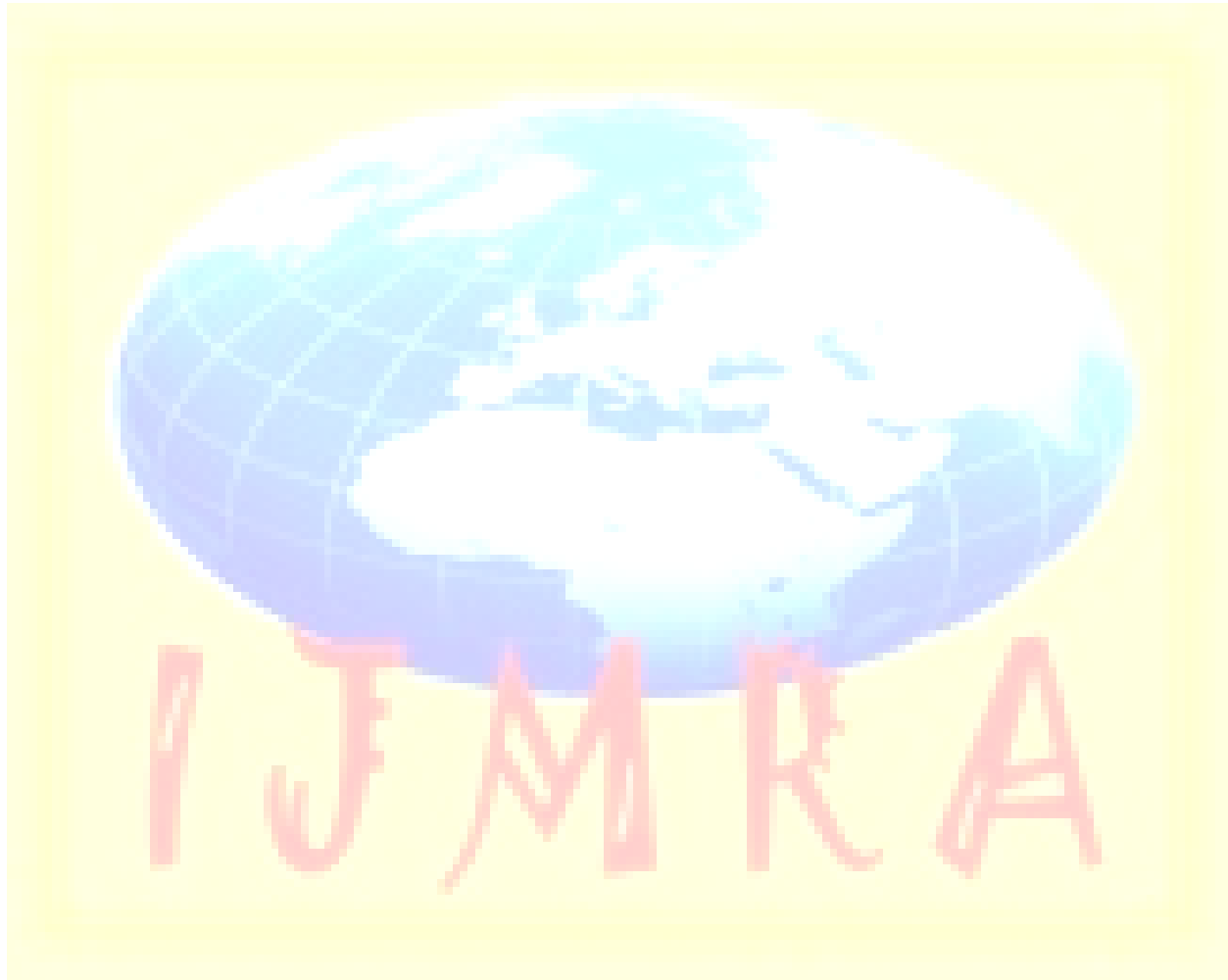

VI. FLOWCHART

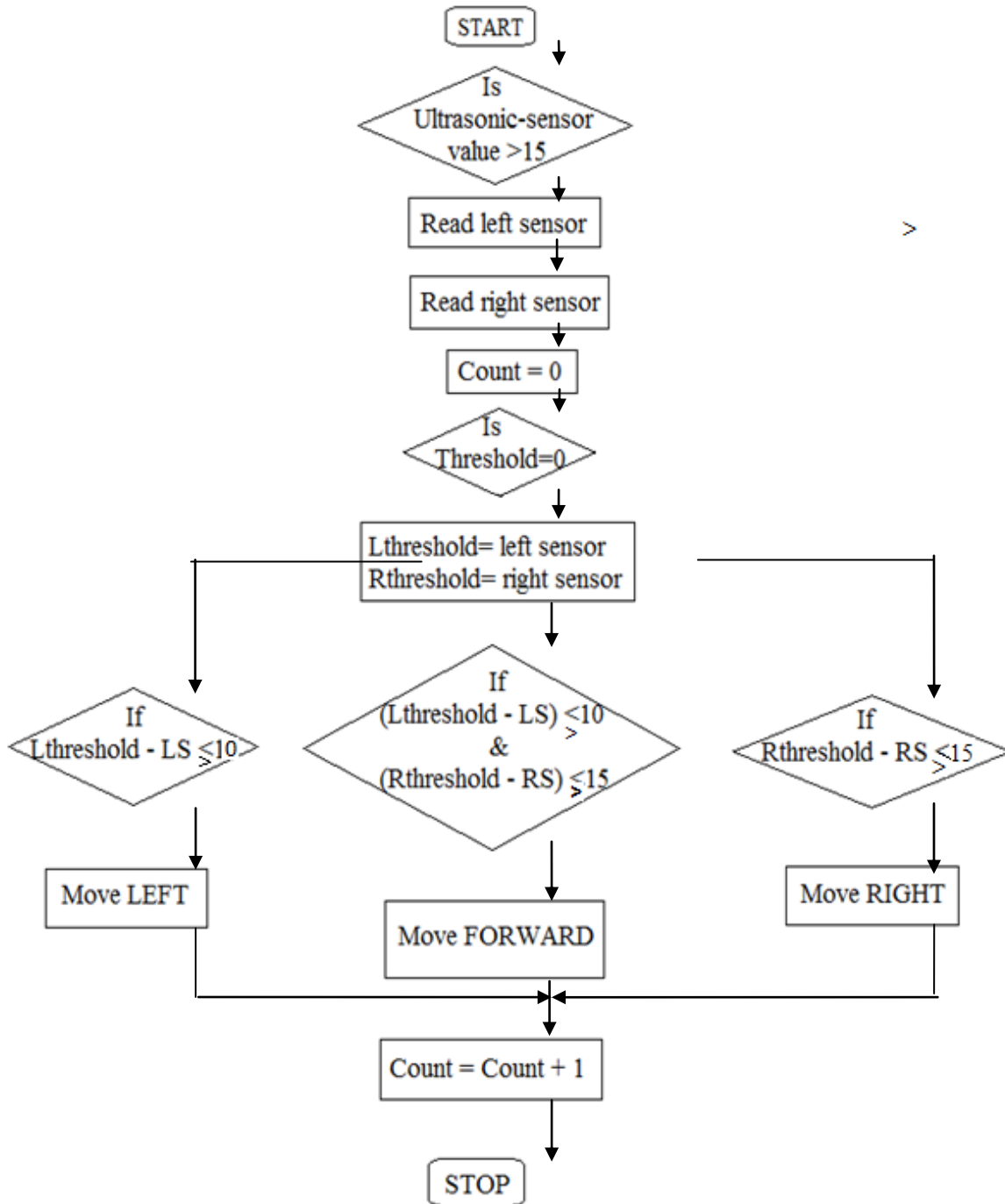

Flow Chart

VII. REFERENCES

- 1) Hari Singh, Dr. Jaswinder Singh; Human Eye Tracking and Related Issues: A Review, International Journal of Scientific and Research Publications, Volume 2, Issue 9, September 2012
- 2) Al-Haddad, A. Sudirman, R. Omar, C. Koo Yin Hui Jimin, M.R. Wheelchair Motion Control Guide Using Eye Gaze and Blinks Based on PointBug Algorithm, Intelligent System Modelling and Simulation(ISMS), 2012 Third International Conference.
- 3) <http://www.creact.co.jp/jpn/por.pdf>
- 4) <http://ncct.in/downloads.html>

