

## DESIGN AND ANALYSIS OF COMPOSITE POPPET VALVE

KAKARAPALLI DIVYA TEJA \*

SRI.P.N.E.NAVEEN\*\*

PROF.T.JAYANANDA KUMAR\*\*\*

### *Abstract:*

Poppet valve work well in engines because the pressure inside the combustion chamber pushes valve against the seat, sealing the chamber and preventing leaks during this cycle poppet valves are exposed to high temperature and pressure which will affect the life and performance of the engine.

The aim of the project is to design a poppet valve with a suitable material for a Four-stroke diesel engine by using fem analysis. In poppet valve we have considered three different materials  $Al_2O_3$ , Carbon-epoxy, Carbon-carbon composite materials.

In this we observe the results of original poppet valve as stress, strain and total deformation. These values are compared with the modified poppet valve design. The modified poppet valve design values are shown tremendous change in Stress, Strain and Total deformation of the composite material.

---

\* Godavari Institute of Engineering and Technology (A), Rajahmundry, Andhra Pradesh, India.

\*\* Godavari Institute of Engineering and Technology (A), Rajahmundry, Andhra Pradesh, India

## INTRODUCTION

A poppet valve is even called as mushroom valve. These valves are basically used to control the timing of gas or vapor flow as well as the quantity which should flow into an engine. These valves consist of a hole, usually round or oval, and a tapered plug. As seen on the valves a disk shape on the end of a shaft is even called as a valve stem. The portion of the hole where the plug meets on the valve is referred as seat or even called as the valve seat. The shaft guides the plug portion by sliding through a valve guide. In exhaust conditions a pressure differential helps to seal the

## INTRODUCTION TO POPPET VALVE:

Safety valves, which are usually of the poppet type, open at a predetermined pressure. The movable element may be kept on its seat by a weighted lever or a spring strong enough to hold the valve closed until the pressure is reached at which safe operation requires opening. On gasoline engines, poppet valves are used to control the admission and rejection of the intake and exhaust gases to the cylinders. The valve, which consists of a disk with a tapered edge attached to a shank, is held against the tapered seat by a compressed spring. The valve is raised from its seat by the action of a rotating cam that pushes on the bottom of the shank, permitting gas flow between a region, which leads to the intake or exhaust pipes, and to region, which leads to the cylinder. The working principles of a 4-stroke poppet valve IC engine cycle are shown schematically in Figure. These are basically divided in to four different strokes in IC engine, the clear description of the strokes is as follows:-

## INTAKE STROKE:

In this stroke the piston moves from the TDC to BDC as shown In the figure, and while the piston moves from the top dead center to bottom dead center, the inlet valve gets opened, and the mixture of air and fuel enters in to the combustion chamber. As the mixture enters the combustion chamber the inlet valve gets closed. This is the first stroke which takes place in the combustion chamber.

## COMPRESSION STROKE:

This is the 2<sup>nd</sup> stroke in the cycle, as in this stroke the piston starts from the bottom dead center and moves towards the top dead center.

- Compression stroke (Figure 1-b), takes place when all the valves are in the closed position and the piston moves in the opposite direction, thereby compressing the gas in the chamber. At the end of this

stroke a spark ignites the mixture or auto-ignition occurs.

- Expansion stroke (Figure 1-c). The gas mixture is ignited in the region of Top Dead Center (TDC). The energy released produces mechanical work, (pushing the piston away), heat and noise. This movement produces friction losses through the engine components and heat that is released to the surrounding metal, coolant and gas.
- Exhaust stroke (Figure 1-d), takes place when the Exhaust Valve Opens (EVO) and the piston moves towards the cylinder head, pushing the burnt gases out of the chamber. Once the Exhaust Valve Closes (EVC) and the piston is close to TDC, the cycle is complete and the intake stroke takes place again on the next cycle.

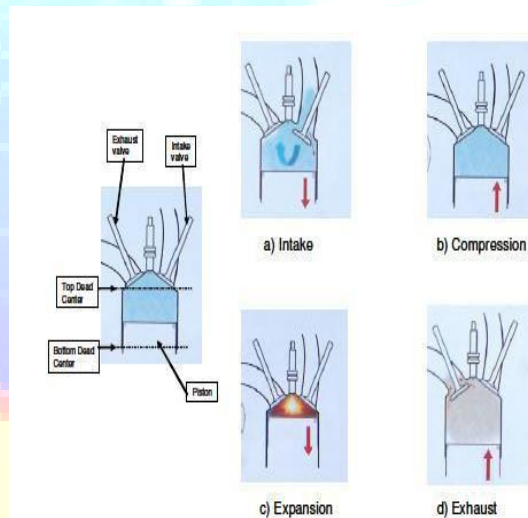

DESIGN OF ORIGINAL VALVE

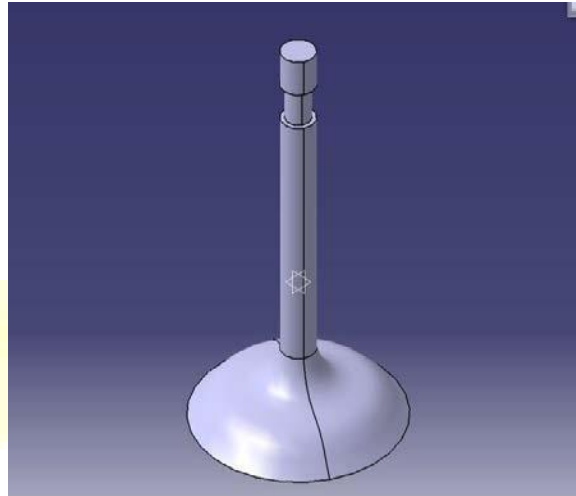

DESIGN OF MODIFIED VALVE

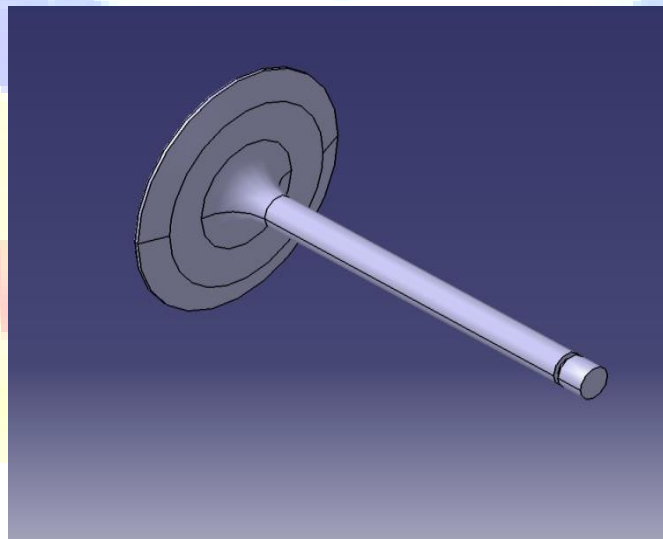

STRUCTURAL ANALYSIS POPPET VALVE WITH AL2O3 MATERIAL

Mesh modal

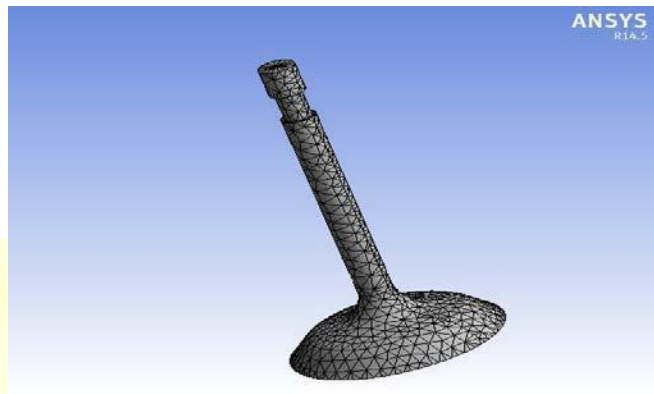

Deformation Results

STRUCTURAL ANALYSIS POPPET VALVE WITH CARBON EPOXY MATERIAL

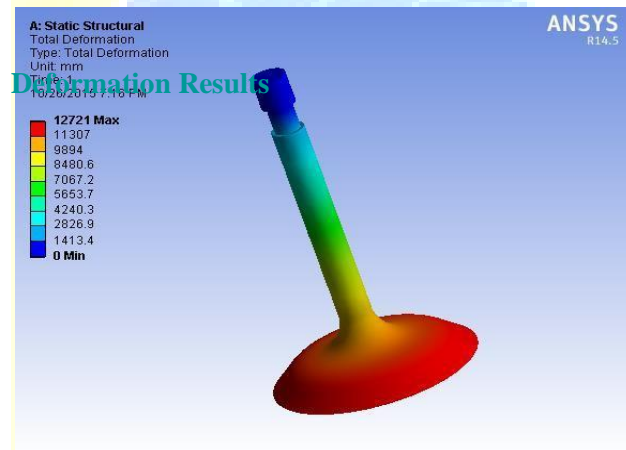

Strain

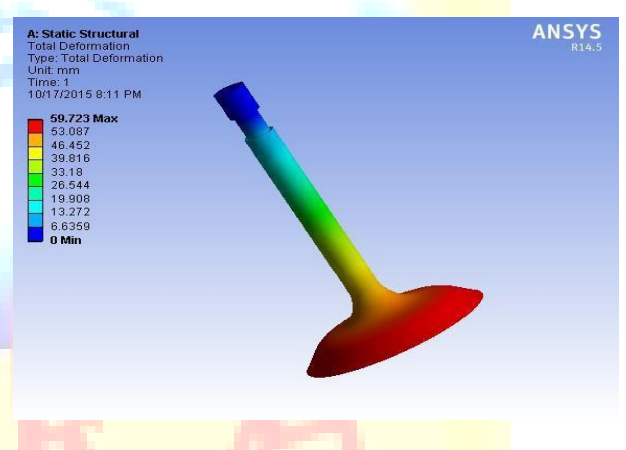

Strain

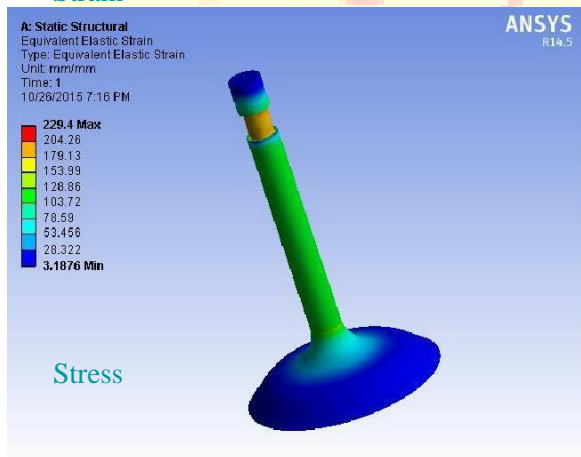

Stress

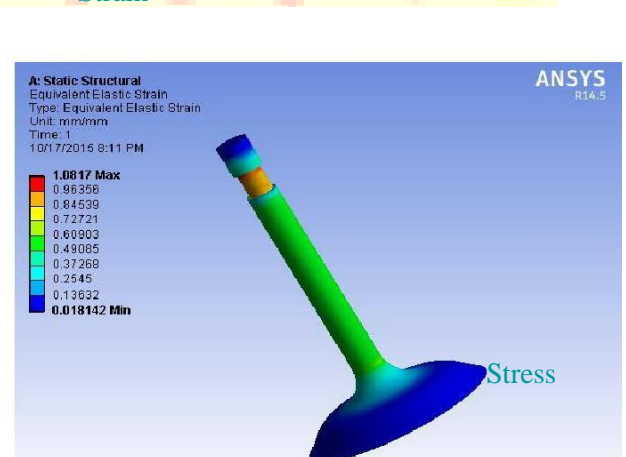

Stress

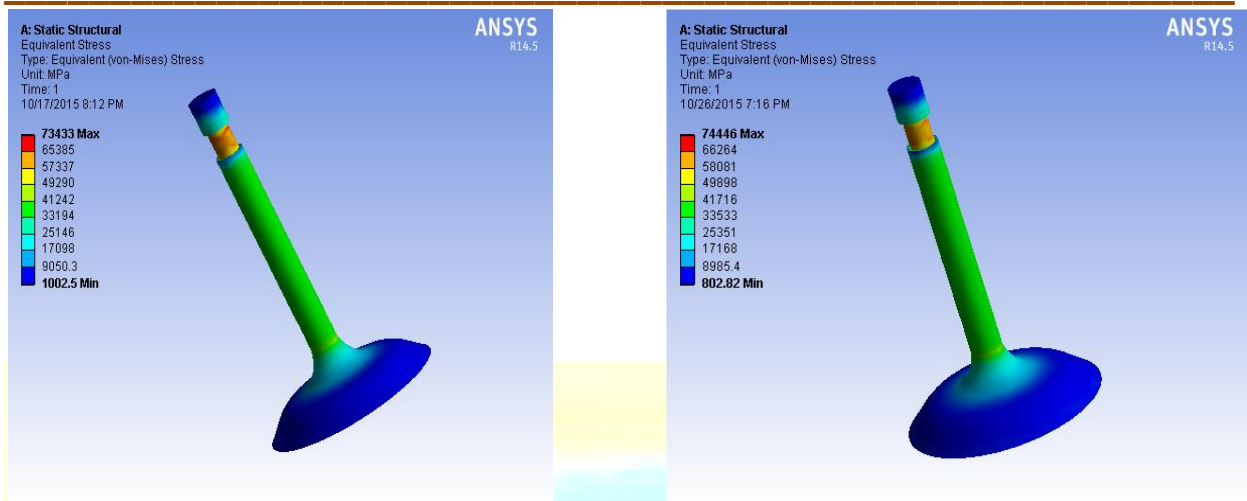

### STRUCTURAL ANALYSIS POPPET VALVE WITH CARBON CARBON COMPOSITE MATERIAL MESH MODEL

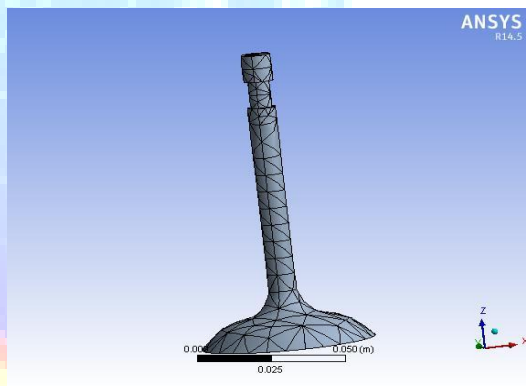

### INPUT DATA

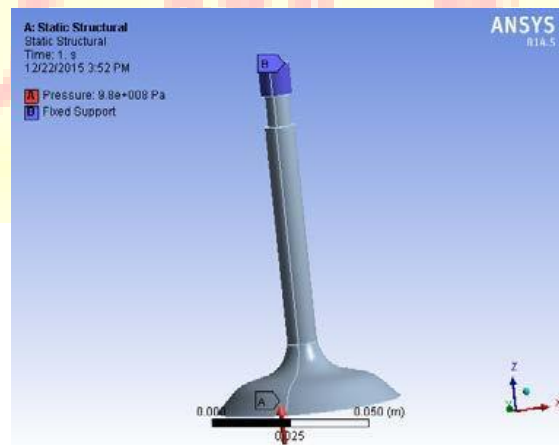

STRESS

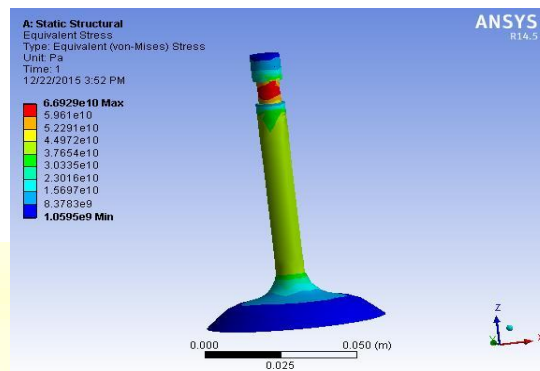

STRAIN

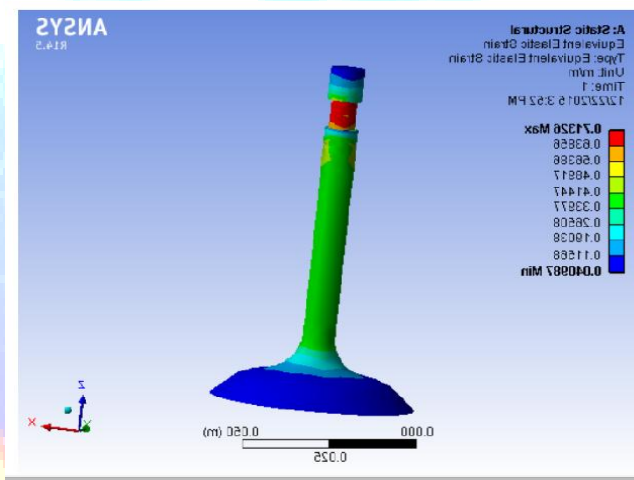

TOTAL DEFORMATION

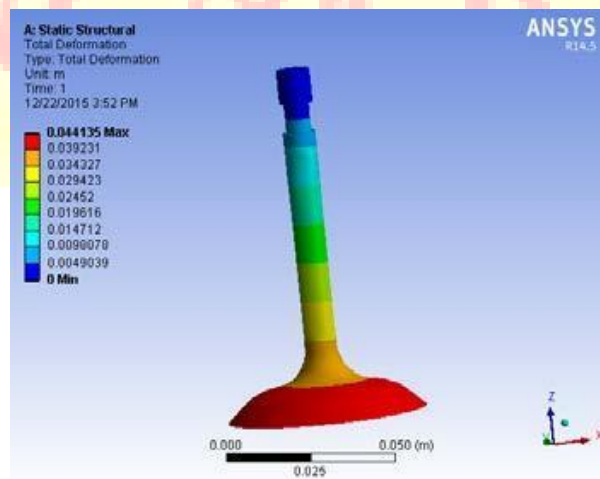

STRUCTURAL ANALYSIS MODIFIED POPPET VALVE WITH AL2 O3 MATERIAL

STRESS

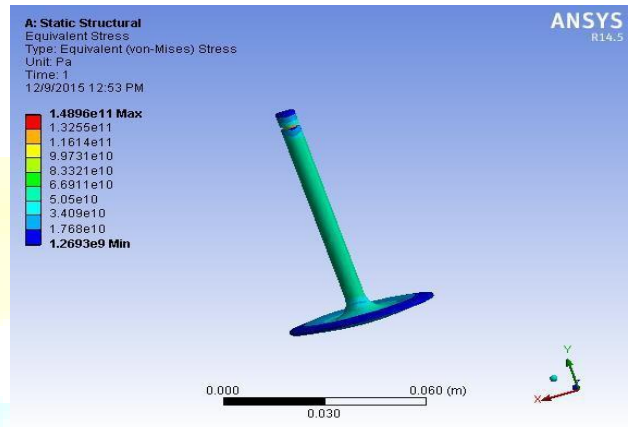

STRAIN

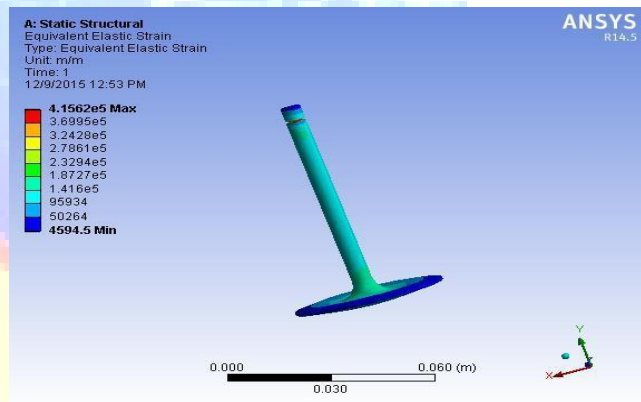

TOTAL DEFORMATION

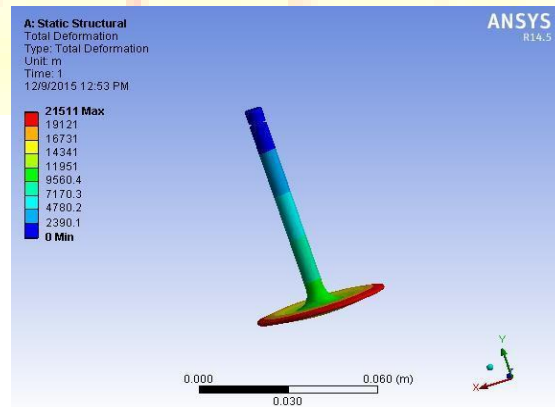



STRUCTURAL ANALYSIS MODIFIED POPPET VALVE WITH CARBON EPOXY MATERIAL  
STRESS

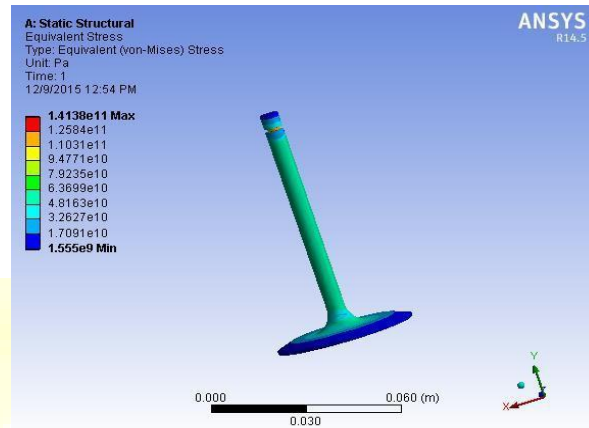

STRAIN

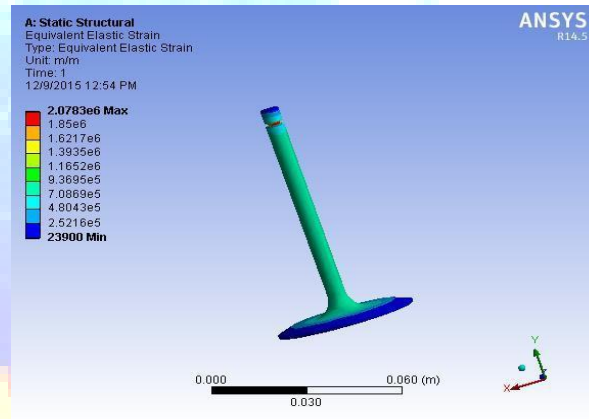

TOTAL DEFORMATION

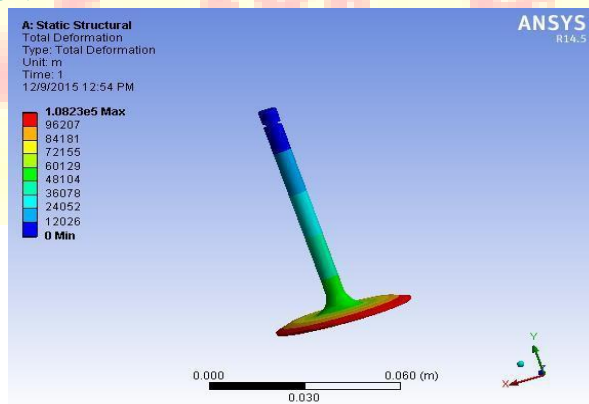

STRUCTURAL ANALYSIS MODIFIED POPPET VALVE WITH CARBON-CARBON COMPOSITE MATERIAL

STRAIN

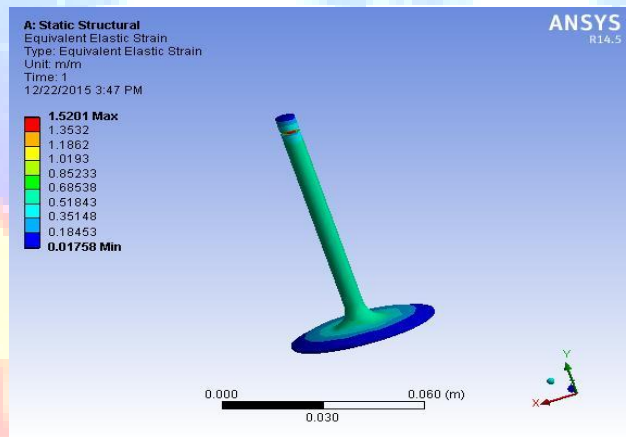
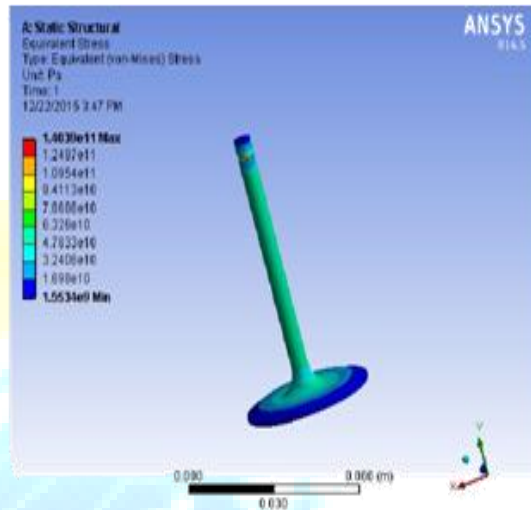

TOTAL DEFORMATION

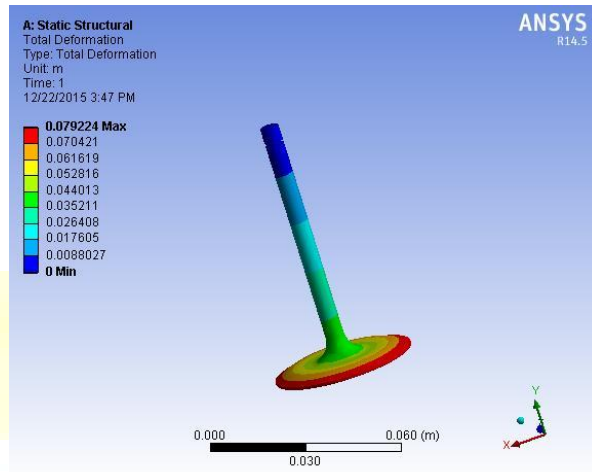

STRUCTURAL ANALYSIS OF POPPET VALVE

TABLE

	DEFORMATION	STRAIN		STRESS	
		MIN	MAX	MIN	MAX
AL2 O3	12721	3.187 6	229. 4	802. 82	7444 6
CAR BON EPO XY	59.723	0.018 142	1.08 17	1002 .5	7343 3
CAR BON CAR BON	0.04413 5	0.040 987	0.71 326	1.06E +09	6.69E +10

STRUCTURAL ANALYSIS MODIFIED POPPET VALVE

TABLE

	DEFORMATION	STRAIN		STRESS	
		MIN	MAX	MIN	MAX
AL2O3	21511	459 4.5	4.16E +05	1.27E +09	1.49E +11
CARBON EPOXY	1.08E+05	239 00	2.08E +06	1.56E +09	1.41E +11
CARBON CARBON	0.079224	0.01 758	1.520 1	1.55E +09	1.40E +11

CONCLUSION

In this thesis, we have considered 3 different materials as Al<sub>2</sub>O<sub>3</sub>, carbon-epoxy, carbon-carbon materials for designing and analysis of poppet valve. We have considered the design in CATIA v5 software and analysis work is carried out in ANSYS software.

The Original poppet valve design values are shown as stress (73433), strain (1.0817) and total deformation (59.723) is having the lesser values. These values are compared with the modified poppet valve. The modified poppet valve design values are shown tremendous change as stress (0.079224), strain (1.5201) and total deformation (1.40E+11) is having the lesser values. These results are obtained for the material carbon-carbon composite material. By these values we can conclude that the modified design carbon-carbon poppet valve shows better performance and life of the original model.

## REFERENCES

- 1) Du, Hongliu, An E/H Control Design for Poppet Valves in Hydraulic System, *ASME, The Fluid Power and Systems Technology Division (Publication) FPST*, Vol. 9, p. 141-148, 2002
- 2) Pfeiffer, Ferris, Dynamics and Stability Issues of Poppet Type Pressure Relief Valves, Master Thesis, *University of Missouri at Columbia*, 2004
- 3) Stone, J. A., Discharge Coefficients and Steady-State Flow Forces for Hydraulic Poppet Valves, *Transactions of the ASME*, 82, p.144-154, March, 1960
- 4) Funk, James E., Poppet Valve Stability, *Journal of Basic Engineering*, Ser. D, Vol.86, p. 207-212, June, 1964
- 5) Kasai, Kohji, On the Stability of a Poppet Valve with an Elastic Support, *Bulletin of JSME*, Vol. 11, No.48, p.1068-1083, 1968
- 6) Johnson, B. L. and D. E. Wandling, Actual Popping Pressure of a Relief Valve with a Real Helical Spring Under Dynamic Load, *Transactions of the ASME*, p. 1142- 1146, November, 1960
- 7) Roberts, Brian J., Poppet Valves for Directional Control, *Machine Design*, 60,18,ABI/INFORM Global, p. 119-122, 11, August, 1988
- 8) Johnston, D. N., K. A. Edge and N.D. Vaughan, Experimental Investigation of Flow and Force Characteristics of Hydraulic Poppet and Disc Valves, *Processing Institution Mechanical Engineering*, Vol. 205, p. 161-170, 1991
- 9) Ito, Kazumi, Koji Takahashi and Kiyoshi Inoue, Flow in a Poppet Valve, *JSME International Journal, Series B: Fluids and Thermal Engineering*, Vol. 36(1), p.42-50, 1993
- 10) Shin, Yung C., Static and Dynamic Characteristics of a Two Stage Pilot Relief Valve, *Transactions of the ASME*, Vol.113, p. 260-268. , June, 1991.

**1. STUDENT**

**Kakarapalli.DivyaTeja** received the B.Tech degree in mechanical engineering from Godavari Institute of Engineering and Technology, JNTU, Kakinada, Andhra Pradesh, India, in 2013 year, and perusing M.Tech in CAD/CAM from Godavari Institute of Engineering and Technology (A), Rajahmundry, Andhra Pradesh, India.

**2. GUIDE 1**

**S P.N.E.Naveen,M.Tech(PhD),Assistant professor,** Godavari Institute of Engineering & Technology(A),Rajahmundry, Andhra Pradesh, India.

**3. GUIDE 2**

**Prof.T.JayanandaKumar PhD, professor,** Godavari institute of Engineering &Technology (A), Rajahmundry, Andhra Pradesh, India.

