

DESIGN OF MYOELECTRIC PROSTHETIC ARM

Chandrashekhar P. Shinde*

Prof. M.S.Kumbhar**

Abstract-

Prosthesis is an artificial extension that replaces a missing body part. Prostheses are typically used to replace parts lost by injury or missing from birth or to supplement defective body parts. . One of the main requirements of artificial arm is that functionally, it should be as near to the natural hand as possible.

Various designs of artificial arm are available in the market, categorised as mechanical, electrical and Myo-electric arm. Myo-Electric arm is stimulated by muscle signal available from the stump of amputee. In this method the MES signals are picked from the surface and the time domain features associated with the intended motion are extracted using suitable technique.

The intended action of the arm is understood from the EMG signal parameters which are obtained by using defined circuit scheme. The pulses are generated by using microcontroller and the respective motor is driven for movements of the hands and wrist, viz . hand open, hand close, wrist flexion, wrist extension etc.

In this research the authors used proportional myoelectric control of a one-dimensional virtual object to investigate differences in efferent control between the proximal and distal muscles of the upper limbs. Restricted movement was allowed while recording EMG signals from elbow or wrist flexors/extensors during isometric contractions. The signals recorded by the surface electrodes are sufficient to control the movements of a virtual prosthesis. The presented method offers great potential for the development of future hand prostheses .

Keywords : Prosthesis , Myo-electric arm , wrist flexion, wrist extension , EMG signals

* PG student

** Head , Dept. of E&TC Rajarambapu Institute of technology ,Rajaramnagar, Dist: Sangali(415414) ,Maharashtra

I. INTRODUCTION:

The objective of this research work was to design and construct a prosthesis that will be strong and reliable, while still offering control on the force exerted. The design had to account for mechanical and electrical design reliability and size. These goals were targeted by using EMG in the electrical control system and a linear motion approach in the mechanical system. The signals recorded by the surface electrodes are sufficient to control the movements of a virtual prosthesis. The presented method offers great potential for the development of future hand prostheses. Myoelectric prosthetic hand enables the user to enact a simple grasp with strength proportional to the contraction of certain muscle group. This paper describes the development of a system that will allow complex grasp shapes to be identified based on natural muscle movement. The application of this system can be extended to a general device controller where input is obtained from forearm muscle, measured using surface electrodes. This system provides the advantage of being less fatiguing than traditional input devices .

This paper describes the design features of artificial limbs that are lightweight, compact and dexterous, that mimics human anatomy and maintain a high lifting capability .These myoelectric signals (MES) can be read by Myoelectrodes and amplified to measure a muscle's naturally generated electricity. After processing via designed processing units , these signals can be designated to control a particular degree of freedom in the prosthesis. Many researchers are working in the development of prosthetic devices to aid the physically challenged people in their routine activities. Active prosthetics devices provide functionality in addition to structural support in place of missing limbs. Myoelectric or electromyogram (EMG) signals that may be acquired using suitable sensors from the human body are widely used in actuating prosthetic devices by intelligently recognizing the intended limb motion of the person. EMG signals may be captured either from the surface of the skin using surface electrodes or from the muscles

The paper is organized as follows. Section II describes the basics of EMG signal generation and acquisition system. Section III outlines the methodology used to design prosthetic arm, Section IV discusses conclusion.

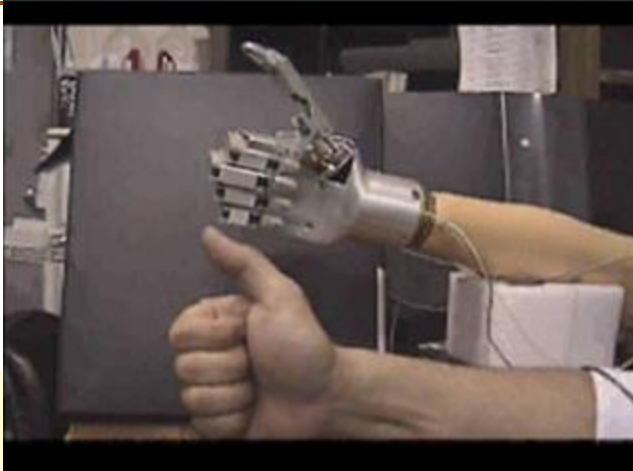

II. GENERATION AND ACQUISITION OF MYOELECTRIC SIGNALS

A . EMG GENERATION.

Under normal conditions, an action potential propagating down a motor neuron activates all the branches of the motor neuron; these in turn activate all the muscle fibers of a motor unit . When the postsynaptic membrane of a muscle fiber is depolarized, the depolarization propagates in both directions along the fiber. The membrane depolarization, accompanied by a movement of ions, generates an electromagnetic field in the vicinity of the muscle fibers. A recording electrode located in this field will detect the potential or voltage (with respect to ground) whose time excursion is known as an action potential. A

schematic representation of this situation is presented in Fig.

In the diagram, the integer n represents the total number of muscle fibers of one motor unit that are sufficiently near the recording electrode for their action potentials to be detected by the electrode. For indwelling needle electrodes, the muscle fibers of the motor unit must be less than 1.5 mm from the electrode . For the sake of simplicity, only the muscle fibers from one motor unit are depicted. The action potentials associated with each muscle fiber are presented on the right side of Fig.1 The superimposition of the signal is as shown in the Fig.

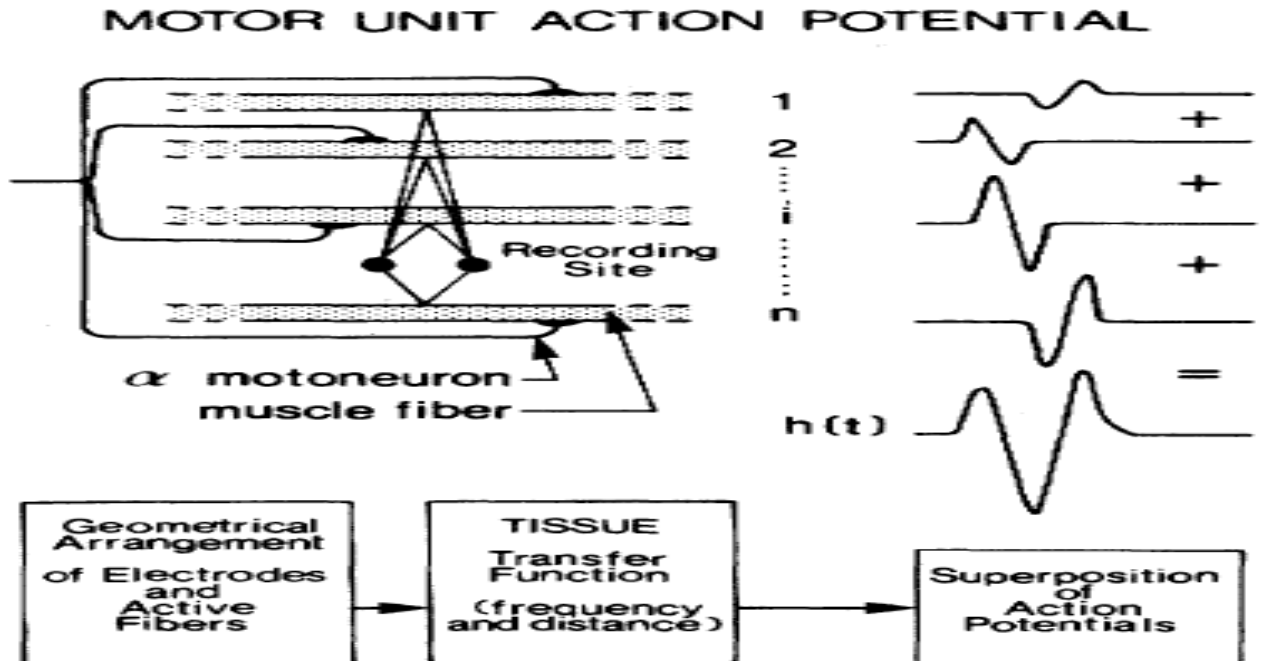

Fig.1 Generation of EMG

B. EMG Signal Acquisition System:

The EMG signals that contain information about the user intention are electrical signals of low amplitude in the frequency range of 10Hz–500Hz. EMG signals for different intended user motions are acquired using a four-channel EMG signal acquisition system, which consists of surface electrodes, ground electrode, protection circuit, instrumentation amplifier, DC rejection filter, variable gain amplifier and band pass filter. The four-channel system will use four such circuits, one for each channel.

Disc electrodes (Ag/AgCl) are placed with a conductive paste on the skin surface of the forearm to acquire the EMG signals. To avoid the 50Hz interference effect (e.g. due to room electrical line interference) on this low amplitude EMG signals, all the four channels are referenced from a common ground electrode. To suppress the radio interference effect, a protection unit is provided with RC filter elements.

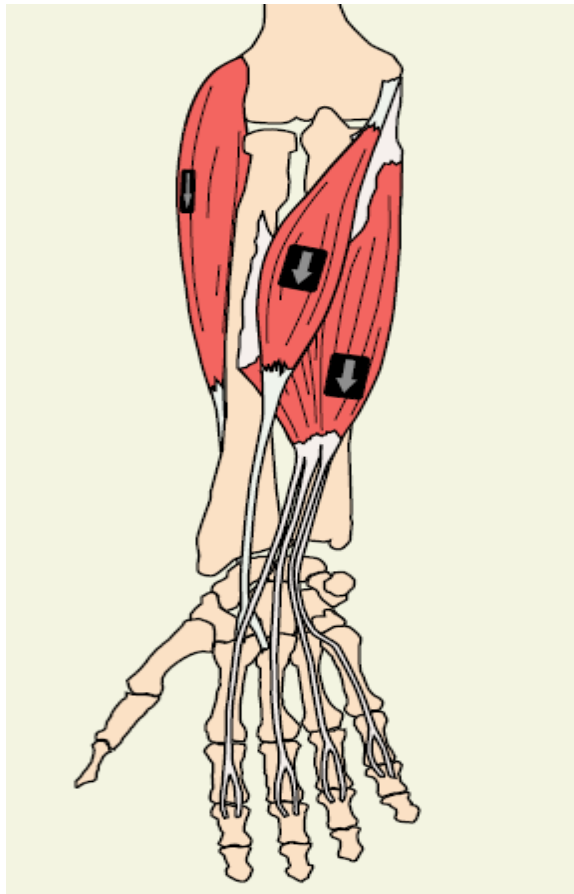

Fig. 2 Placement of electrodes

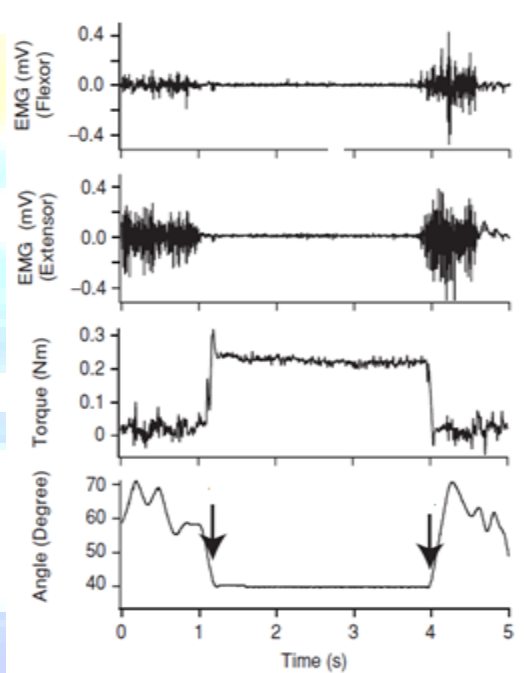

Fig.3 Time profiled EMG signal for light weight grab

This low amplitude EMG signals is amplified through **INA118-P** instrumentation amplifier. This amplifier has a very high input impedance and high common mode rejection ratio. Normally, these signals may have DC components which are suppressed by DC rejection filter circuit. Output of the DC rejection filter is amplified and passed through a band pass filter to obtain the signals of frequency range of 10Hz-500Hz. This is achieved through the two-pole high-pass and two-pole low-pass filters with a gain of 4.

III . METHODOLOGY:

Fig.4 shows a block diagram of the myoelectrically controlled partial-hand prosthesis system. The electrodes are attached to the biceps. Biceps consist of bundles of skeletal fibers. When the fibers extend along the length of the muscle, the extracellular field potential is evoked. The extracellular field potential is an EMG and has a brief duration of 3–15 ms. The typical amplitude of EMG ranges from 20–2000 V, depending on the size of the motor unit and the position of the electrode. The EMG signals generated from a contracting muscle and detected by physiological signal electrodes are first sent to the instrumentation amplifier, the bandpass filter, and the precision rectifier circuits. Following amplification, filtering, and rectification, the resulting signals are used as inputs to the microcontroller and are converted to digital ones by a 1-b analog comparator embedded in the microcontroller. According to the digital signals, the program built in the microcontroller can make precise decisions and then output PWM signals to control the R/C servomotor to drive the prosthesis.

After several iterations of pretesting electrode efficiency, passive electrodes were adopted in this project for economy and convenience. The selected electrodes must meet the following requirements:

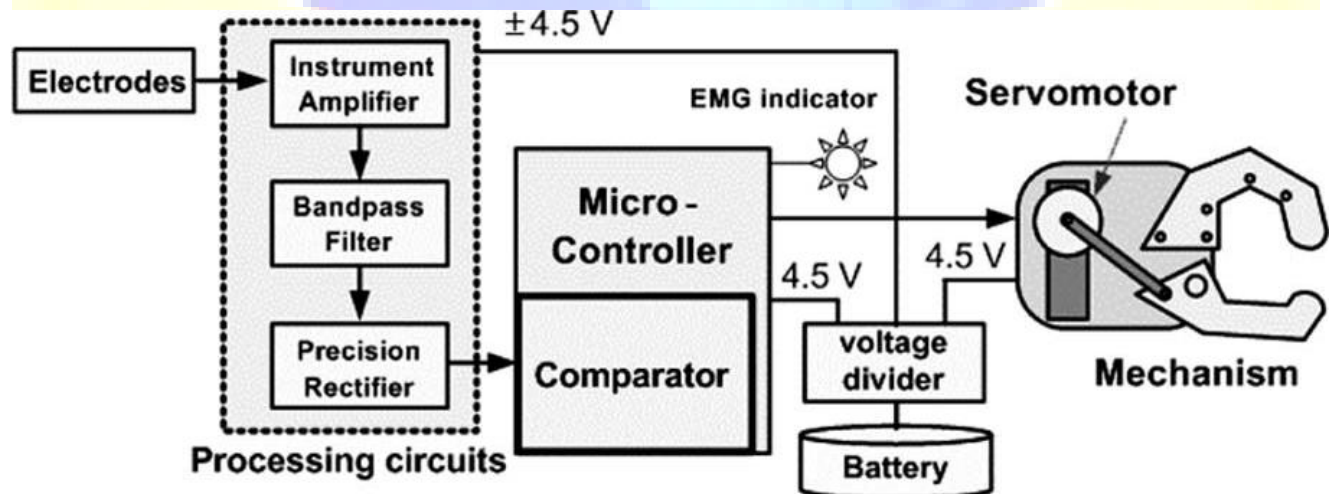

Fig. 4 Block presentation of proposed designed prosthetic arm

1) include conductive adhesive hydrogel; 2) have a high-quality foam substrate that resists fluids and conforms easily to the skin, to ensure excellent trace quality; 3) be small for convenient lead

placement; 4) be teardrop-shaped for easy release and removal; 5) have a perforated liner that allows the electrodes to be divided into strips; 6) support multiple packaging configurations.

The Burr–Brown INA-118P amplifier is used as a first stage differential amplifier with a gain of 20. This amplifier exhibits a high common-mode rejection ratio (CMRR) and effectively reduces noise .

A bandpass filter with gain=150, consisting of a high-pass and a low-pass filter, was designed with a low power op amp LF351 (National Semiconductor). The cutoff frequency of the low-pass filter was 500 Hz while that of the high-pass filter was 50 Hz. Meanwhile, the total gain of the combination of the instrument amplifier and the bandpass filter was 20x150. This gain is high enough to amplify the obtained EMG.

A servomotor commonly used for control applications consumes much current and is oversized and expensive. Because a stepping motor loses step under some conditions, it is unsuitable in this application. Besides,

servomotors and stepping motors must be controlled by external driver circuits. The R/C servomotor is controlled by a PWM signal, which can drive the motor to a desired position according to the width of the pulse.

Given a 0.5–2.5-ms pulse width, the R/C servomotor can rotate from -90° to $+90^{\circ}$ clockwise. The output shaft of the servomotor can drive the linkage so that the movable part of the prosthesis rotates with respect to the swivel and then closes the palm of the prosthesis. The output torque of the servomotor is approximately 3 kg-cm so that the designed prosthesis can easily grasp an object that weighs 1 kg.

A CMOS-based 8-b Atmel AT89C1051 single-chip serves as the microcontroller of the system; it accepts the processed EMG signals and is programmed to control the R/C servomotor. The 1-b embedded analog comparator allows the processed analog EMG signals to be converted into digital ones. The conversion rate of the 1-b comparator is 10 s.

IV. CONCLUSION:

Use of EMG signals for control of prosthetic limbs has been historically plagued by unreliability of the surface EMG sensors due to movement artifacts, wire breakage, inconvenience of doffing and donning electrodes, maintenance of skin condition, and repeatability of placement. In addition it is difficult to obtain more than 2-3 degrees of freedom from the extracorporeal surface. The control of

powered upper limb prostheses has not seen any revolutionary developments since its inception, but rather, incremental evolution. This paper represents progress toward a more natural, more effective means of myoelectric control by providing high accuracy, low response time, and an intuitive control interface to the user.

In this work, the authors developed a EMG acquisition system with reduced noise and interference effect to acquire the EMG signal through surface electrodes. From the acquired EMG signals, intended motions are identified through time domain features. This study demonstrated that it is feasible to apply a myoelectrically controlled prosthetic arm system providing external torque to the affected wrist joint for subject after loss of natural arm . The primary feature of this system was that the subject's effort could be detected from his/her EMG signal and was directly linked to the assistance from the prosthetic arm system. Subject could voluntarily control both their own affected wrist joint and the prosthetic system.

In future , more precise prosthetic control can be obtained by using feature extraction and classification of EMG signal using suitable tools.

V. REFERENCES:

- [1] C. Fraser and J. Milne, *Integrated Electrical and Electronic Engineering for Mechanical Engineers*. New York: McGraw-Hill, 1994.
- [2] D. Shetty and R. A. Kolk, *Mechatronics System Design*. Boston, MA:PWS-Kent, 1997.
- [3] D. G. Shurr and T. M. Cook, *Prosthetics and Orthotics*, 2nded. Englewood Cliffs, NJ: Prentice-Hall, 2002, pp. 150–155.
- [4] C. C. Nielsen, “A survey of amputees: Functional level and life satisfaction ,information needs, and the prosthetist’s role,” *J. Pros. Orth.*, vol.3, pp. 125–129, 1989.
- [5] W. Ganong, *Review of Medical Physiology*, 20th ed. New York: Mc-Graw-Hill, 2001, pp. 72–74.
- [6] J. H. Kuo, “Development of a controller for artificial arm via EMG pattern recognition,” M.S. thesis (in Chinese), Institute of Electrical Engineering, National Taiwan Univ., Taipei, 1995.
- [7] Noraxon Inc., www.Noraxon.com/emg/php3. Accessed Jan. 2008.
- [8] B. Hudgins, P. A. Parker, and R. N. Scott, “A new strategy for multifunction myoelectric control,” *IEEE Transl. J. Biomed. Eng.*, vol.40, no. 1, pp. 82–94, Jan. 1993.

- [9] J. G. Webster, *Medical Instrumentation: Application and Design*, 3rd ed. New York: Wiley, 1998, pp. 121–182.
- [10] Burr–Brown IC Data Book, Linear Products, pp. 4.124–4.134, 1997.
- [11] A. S. Sedra and K. C. Smith, *Microelectronic Circuits*, 4th ed. New York: Oxford Univ. Press, 1998.
- [12] S. Franco, *Design With Operational Amplifiers and Analog Integrated Circuits*. New York: McGraw-Hill, 1988.

