

UNMANNED AERIAL VEHICLE SPRAYING FERTILISERS AND PESTICIDES ON AGRICULTURE FIELDS

Chandbadshah S B V J*

R Rakesh*

Abstract

Keywords:

Agriculture;

Aerial Vehicle;

Fertilisers;

Quad copter;

Unmanned

The paper objective was to design a semi-autonomous Quad copter capable of self-sustained flight via wireless communications while utilizing a microcontroller. The Quad copter was designed to be small enough so that costs would be minimized, which is why small motors and propellers are being used. While a PIC microcontroller, accelerometer, and gyroscope are communicating between each other to maintain control. The scheduler program arranges the following tasks: controller input, sensor data received from the accelerometer, Gyroscope, and Magnetometer. The wireless transceivers use SPI to send control signals to the microcontroller on the quad copter from the handheld controller unit. The accelerometer/gyroscope and magnetometer both use I2C to send the amount of acceleration, stabilization, and the direction vector. To achieve flight, two of the motors must apply downward force and the other two motors have to apply an upward force. To turn, one pair (left or right side) of motors slows down to turn the copter. To ascend, all motors will increase in speed, and will all decrease in order to descend. To move forward, the front two motors will decrease while the back two motors will increase. And vice versa in order to move in a backwards direction.

* Assistant Professor Dept of ME Annanacharya Institute of technology & science Triupati, India

1. Introduction

Humans are fascinated by levitation. The reason is probably that the world we are living in is three-dimensional. However, human beings live and move mainly in two dimensions. It seems that humans have a very strong drive to overcome their biological limits. This leads to build machines that enable them to move in three-dimensional space, e.g., airplanes and helicopters. No matter how complicated the geographical feature is, it doesn't become a trouble if it flies in the air. What's more, it is possible to use it even in a considerably severe region. And it can be controlled remotely to carry out a wide range of investigations. Unmanned Aerial Vehicles (UAVs) are crafts capable of flight without an onboard pilot. They can be controlled remotely by an operator or can be controlled autonomously via pre-programmed flight paths. A quad-rotor helicopter (i.e. QUADCOPTER) is an aircraft whose lift is generated by four rotors. Control of such a craft is accomplished by varying the speeds of the four motors relative to each other. Quad-rotor crafts naturally demand a sophisticated control system in order to allow for balanced flight. Uncontrolled flight of a quad-rotor would be virtually impossible by one operator, as the dynamics of such a system demand constant adjustment of four motors simultaneously.

2. Research Methodology, Materials and Components

The major components that are used in the Drone for seed dropping application are as follows, Brushless motor, Battery, Speed controller, Servo motor, Multi controller unit, Remote transmitter and receiver, Connecting wires.

2.1 Electronic Speed Controller

The purpose of a motor speed controller is to take a signal representing the demanded speed, and to drive a motor at that speed. With the purpose to vary an electric motor's speed and direction ESCs are often used on electrically-powered radio controlled models. An ESC can be a stand-alone unit which plugs into the receiver's throttle control channel or incorporated into the receiver itself, as is the case in most toy-grade R/C vehicles. Some R/C manufacturers that install proprietary hobby-grade electronics in their entry-level vehicles, vessels or aircraft use onboard electronics that combine the two on a single circuit board.

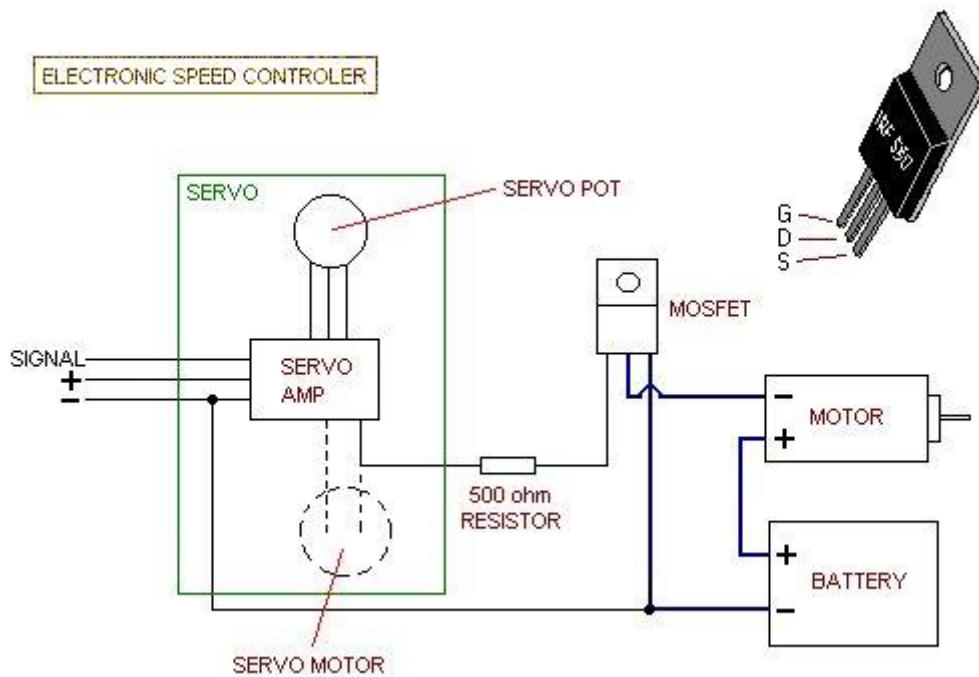

Figure.1 *Electro speed controller*

2.2 Function

Regardless of the type used, an ESC interprets control information not as mechanical motion as would be the case of a servo, but rather in a way that varies the switching rate of a network of field effect transistors, or FETs. The rapid switching of the transistors is what causes the motor itself to emit its characteristic high-pitched whine, especially noticeable at lower speeds. It also allows much smoother and more precise variation of motor speed in a far more efficient manner than the mechanical type with a resistive coil and moving arm once in common use. Most modern ESCs incorporate a battery eliminator circuit (or BEC) to regulate voltage for the receiver, removing the need for receiver batteries. BECs are usually either linear or switched mode voltage regulators.

DC ESCs in the broader sense are PWM controllers for electric motors. The ESC generally accepts a nominal 50 Hz PWM servo input signal whose pulse width varies from 1 ms to 2 ms. when supplied with a 1 ms width pulse at 50 Hz, the ESC responds by turning off the DC motor attached to its output. A 1.5 ms pulse-width input signal results in a 50% duty cycle output signal

that drives the motor at approximately half-speed. When presented with 2.0 ms input signal, the motor runs at full speed due to the 100% duty cycle (on constantly) output.

2.3 Dc Motors

An electric motor is a machine which converts electrical energy to mechanical energy. Its action is based on the principle that when a current-carrying conductor is placed in a magnetic field, it experiences a magnetic force whose direction is given by Fleming's left hand rule.

When a motor is in operation, it develops torque. This torque can produce mechanical rotation. DC motors are also like generators classified into shunt wound or series wound or compound wound motors.

A DC motor is an electric motor that runs on direct current (DC) electricity. In any electric motor, operation is based on simple electromagnetism. A current-carrying conductor generates a magnetic field; when this is then placed in an external magnetic field, it will experience a force proportional to the current in the conductor, and to the strength of the external magnetic field. As you are well aware of from playing with magnets as a kid, opposite (North and South) polarities attract, while like polarities (North and North, South and South) repel. The internal configuration of a DC motor is designed to harness the magnetic interaction between a current-carrying conductor and an external magnetic field to generate rotational motion.

A dc motor can be broadly classified into two distinguished types of motors namely -:

- Brushed dc motor
- Brushless dc motor

As per our project we will be concentrating more on the concept of brushless dc motor.

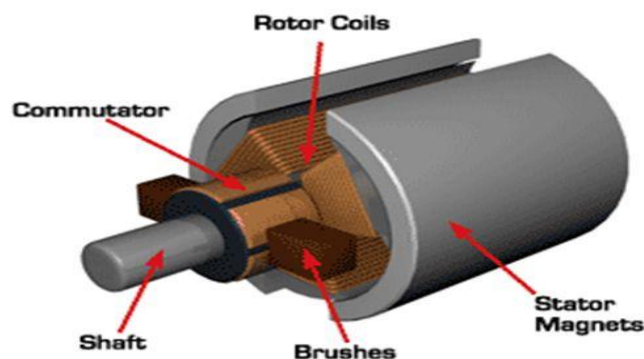

Figure 2. DC Motor

2.4 Brush Less Motor

Brushless DC electric motor (BLDC motors, BL motors) also known as electronically commutated motors (ECMs, EC motors) are synchronous motors that are powered by a DC electric source via an integrated inverter/ switching power supply, which produces an AC electric signal to drive the motor. In this context, AC, alternating current, does not imply a sinusoidal waveform, but rather a bi-directional current with no restriction on waveform. Additional sensors and electronics control the inverter output amplitude and waveform (and therefore percent of DC bus usage/efficiency) and frequency (i.e. rotor speed). The rotor part of a brushless motor is often a permanent magnet synchronous motor, but can also be a switched reluctance motor, or induction motor.

Brushless motors may be described as stepper motors; however, the term stepper motor tends to be used for motors that are designed specifically to be in a mode where they are frequently stopped with the rotor in a defined angular position. This page describes more general brushless motor principles, though there is overlap.



Figure 3. *Brushless dc motor*

2.5 Multi Controller Units

In automotive electronics, ElectronicControlUnit (ECU) is a generic term for any embedded system that controls one or more of the electrical system or subsystems in a motor vehicle.

Types of ECU include Electronic/engine Control Module (ECM), Power train Control Module (PCM), Transmission Control Module (TCM), Brake Control Module (BCM or EBCM), Central Control Module (CCM), Central Timing Module (CTM), General Electronic Module (GEM), Body Control Module (BCM), Suspension Control Module (SCM), control unit, or control module. Taken together, these systems are sometimes referred to as the car's computer.

Technically there is no single computer but multiple ones. Sometimes one assembly incorporates several of the individual control modules.

Some modern motor vehicles have up to 80 ECUs. Embedded software in ECUs continues to increase in line count, complexity, and sophistication. Managing the increasing complexity and number of ECUs in a vehicle has become a key challenge for original equipment manufacturers (OEMs).

Controller Board Block Diagram

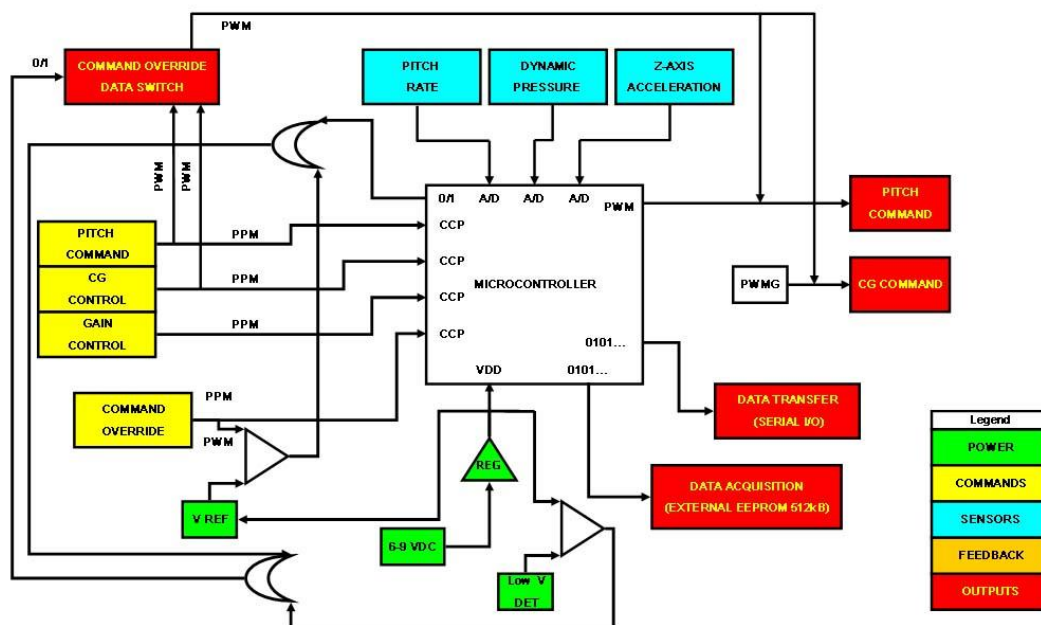

Figure.4 Micro controller unit

2.6 Pesticide and Its Container

Pesticides are substances meant for attracting, seducing, and then destroying any pest. They are a class of biocide. The most common use of pesticides is as plant protection products (also known as crop protection products), which in general protect plants from damaging influences such as weeds, fungi, or insects.

This use of pesticides is so common that the term pesticide is often treated as synonymous with plant protection product, although it is in fact a broader term, as pesticides are also used for non-agricultural purposes. The term pesticide includes all of the following: herbicide, insecticide, insect growth regulator, nematicide, termiticide, molluscicide, pesticide, avicide, rodenticide, predacide, bactericide, insect repellent, animal repellent, antimicrobial, fungicide, disinfectant(antimicrobial), and sanitizer. These pesticides are stored in the container in this project for the spraying application of them inside the farm.

2.7 Radio Transmitter and Receiver

In electronics and telecommunications a radio transmitter is an electronic device which, with the aid of an antenna, produces radio waves. The transmitter itself generates a radio frequency alternating current, which is applied to the antenna. When excited by this alternating current, the antenna radiates radio waves. The term transmitter is usually limited to equipment that generates radio waves for communication purposes; or radiolocation, such as radar and navigational transmitters. A transmitter can be a separate piece of electronic equipment, or an electrical circuit within another electronic device. A transmitter and receiver combined in one unit are called a transceiver.

The term transmitter is often abbreviated “XMTR” or “TX” in technical documents. The purpose of most transmitters is radio communication of information over a distance. The information is provided to the transmitter in the form of an electronic signal, such as an audio (sound) signal from a microphone, a video (TV) signal from a TV camera, or in wireless networking devices a digital signal from a computer. The transmitter combines the information signal to be carried with the radio frequency signal which generates the radio waves, which is often called the carrier. This process is called modulation.

A radio transmitter is an electronic circuit which transforms electric power from a battery or electrical mains into a radio frequency alternating current, which reverses direction millions to

billions of times per second. The energy in such a rapidly-reversing current can radiate off a conductor (the antenna) as electromagnetic waves (radio waves).

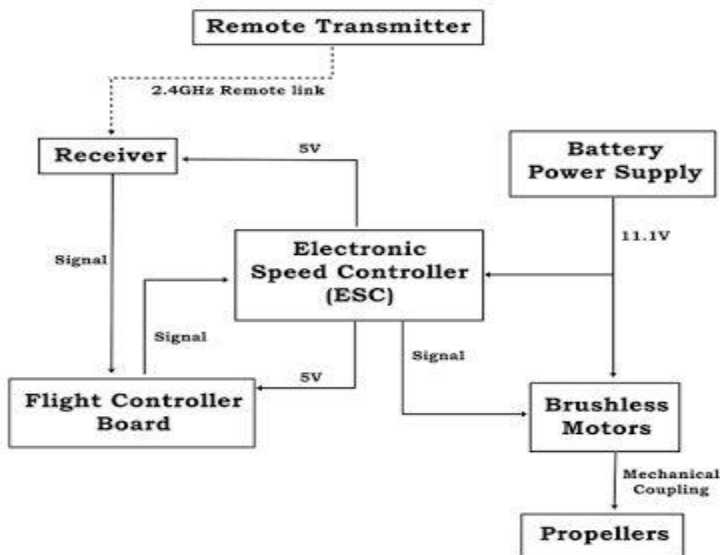

Figure.5 Remote Transmitter line diagram

2.8 Receiver (Rx)

A radio receiver is an electronic circuit that receives its input from an antenna, uses electronic filters to separate a wanted radio signal from all other signals picked up by this antenna, amplifies it to a level suitable for further processing, and finally converts through demodulation and decoding the signal into a form usable for the consumer, such as sound, pictures, digital data, measurement values, navigational positions, etc. Demodulation is the act of extracting the original information-bearing signal from a modulated carrier wave.

A demodulator is an electronic circuit that is used to recover the information content from the modulated carrier wave.

The receiver in information theory is the receiving end of a communication channel. It receives decoded messages/information from the sender, who first encoded them. Sometimes the receiver is modeled so as to include the decoder. Real-world receivers like radio receivers cannot be expected to receive as much information as predicted by the noisy channel coding theorem.

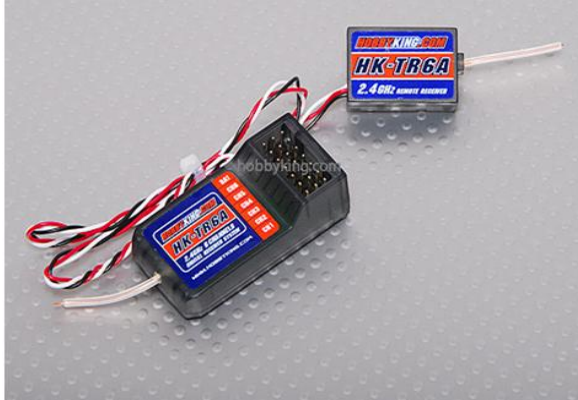
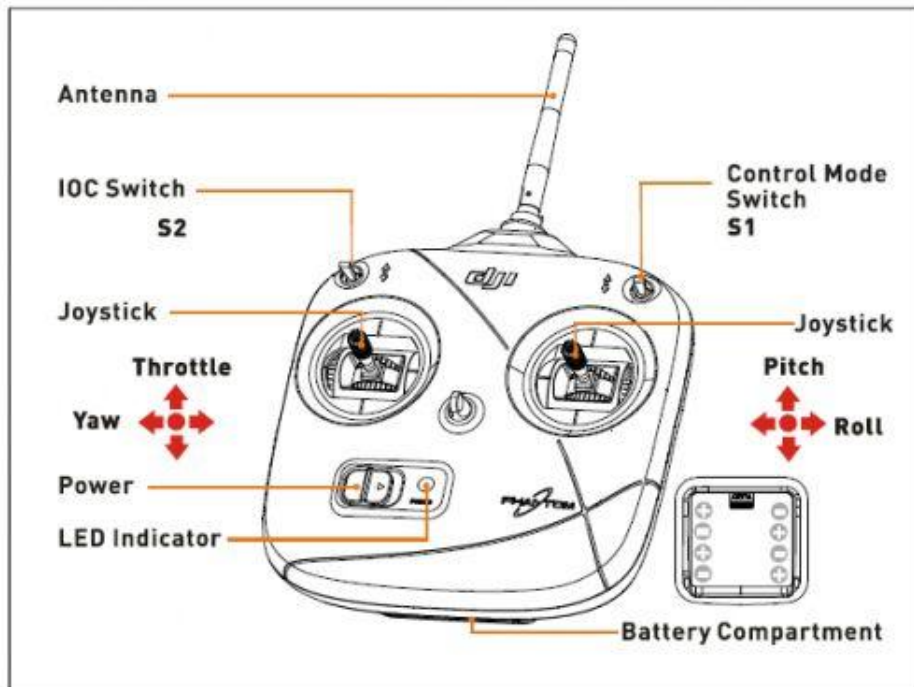
Figure.6 *hkt6a Receiver*Figure.7 *Remote transmitter*

2.9 Battery

A D battery (D cell or IEC R20) is a size of dry cell. A D cell is cylindrical with an electrical contact at each end; the positive end has a nub or bump. D cells are typically used in high current drain applications, such as in large flashlights, radio receivers and transmitters, boom boxes, products with electric motors, safety systems, Geiger counters, megaphones, or other applications that require an extended running time. A D cell may be either rechargeable or non-rechargeable. Its terminal voltage and capacity depend upon its cell

chemistry. The National Carbon Company introduced the first D cell in 1898. Before smaller cells became more common, D cells were widely known as flashlight batteries. The U.S. military designation for this battery has been BA-30 since sometime before WWII. During World War II it was designated the Type C battery by the Navy leading to confusion with the smaller C cell battery (BA-42). In 2007, D batteries accounted for 8% of alkaline primary battery sales (numerically) in the US. In 2008, Swiss purchases of D batteries amounted to 3.4% of primary and 1.4% of secondary sales.

2.10 Propellers Used

We have used 2 Blade, rotating and counter rotating propellers. Benefits of using a 3 blade propeller over 2 blades is that we get more blade area because of which the blade can transfer more power onto the air, thus providing more lift. We are using two different kinds of blades one rotating in clockwise directions and other rotating in anti-clockwise direction, thus producing force in opposite directions.

3. Experiment and Components Assembly (10pt)

3.1 Assembly Process

The basic principle of the drone or the quad copter is like that of the remote controlled RC plane. This has a Radio transmitter with the user, who controls the motion of the quad copter and the Frequency receiver is kept at the drone or the copter for the movement of the drone.

The remote transmitter is a 4-channel radio transmitter. When the input in the form of the transmission signals is given or the transmitter is operated with the keys, the receiver switches on and it makes the supply from the battery power to reach the brushless motor for the rotational motion of the fan in the motor and when the flying button is operated, the quad copter can fly and then it travels along the path of through where it is actuated.

The quad copter consists of the pesticide container or the pesticide box at its bottom side of the copter. The compartment can be opened only using the servo motor. The servo motor also has a control in the Radio transmitter and receiver. When the servo motor is actuated, it makes the compartment of the pesticide container open and then allows the pesticide box to spray it on the farm.

3.2 Component Specifications

BLDC Motor:

- 1 Rated Capacity. 60KW.
- 2 Input Voltage. 380 - 415V AC, 3 Φ , 50Hz.
- 3 Rated Current (Max.) 100 Amp.

Specification:

Multi-Rotor control board 18~30A
 Brushless ESC x 4 2200~3300mAh 3~4S
 Li poly 28~35 Size 700~1100KV
 Brushless motor x 4 9x4.7~12x5
 Propeller - 2 standard/2 reverse rotation 4ch Transmitter/Receiver

Frame:

Width: 550mm
 Height: 240mm (without dome cover)
 Frame Weight: 400g (without electronics)

Quad Copter:

5010 360kv motors with 1555 CF props
 Customized Aluminum Frame
 Pixhawk flight controller with ubloxgps, led
 Telemetry Modules 433 MHz > 1 Km range
 FS-i6 6 Channel Radio ~ 1 Km range
 22.2V (6S) 2200mAh 30C Li-Po battery
 Imax B6 AC charger

Table1. Major Components Used

Sl. No.	PARTS	Qty.	Material
1	Fan	1	Steel
2	Brushless DC motor	1	380 - 415V AC
3	Battery	1	Li
4	Radio receiver	1	-
5	Pesticide controller	1	-
6	Relay unit	1	-
7	Micro control unit	-	-
8	Centrifugal pump	-	Steel

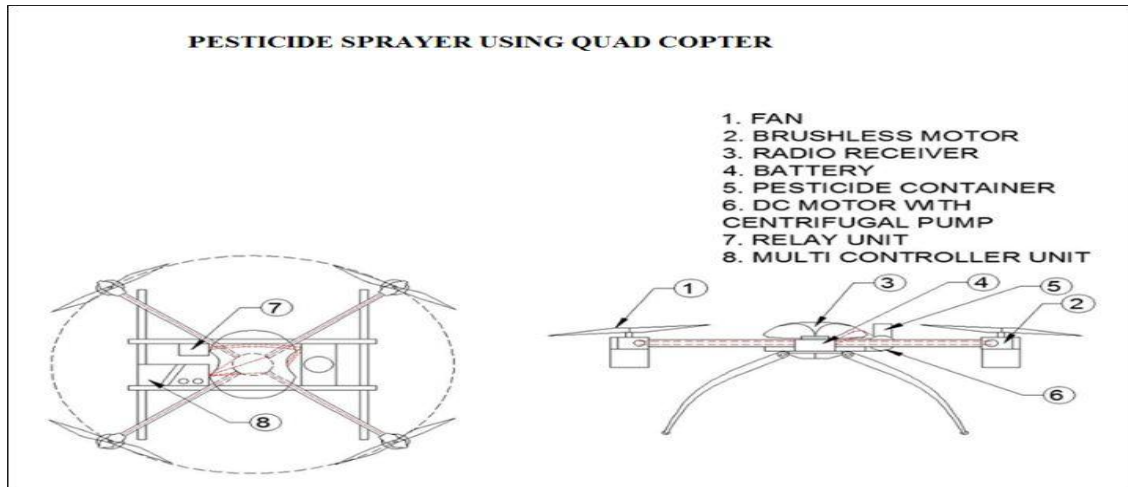

Figure 8. Overall Block Diagram of Pesticide Sprayer

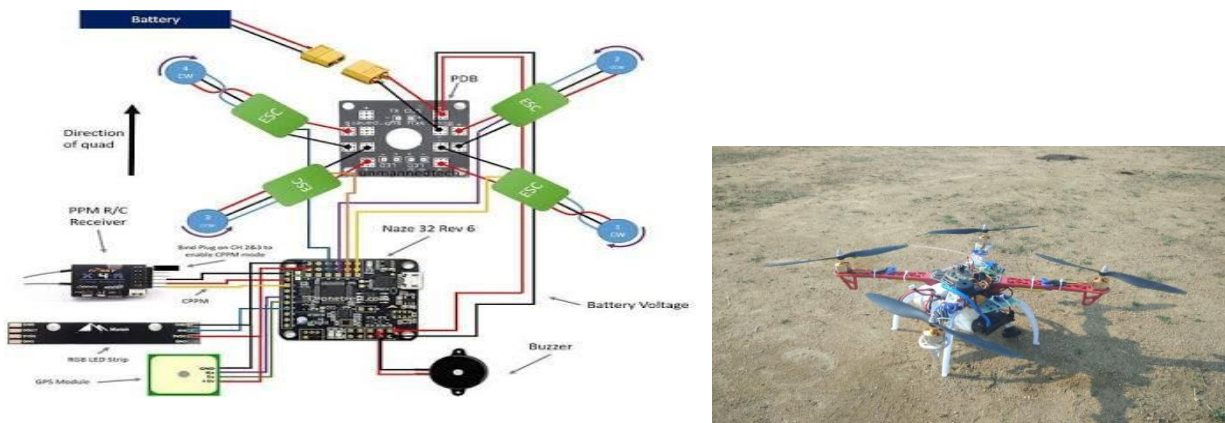

Figure 9. Overall 3D Block Diagram of Pesticide Sprayer

3.3 Advantages

- It is easy to operate,
- Seeds can be easily dropped in the land,
- It requires less manual effort.

3.4 Disadvantages

- It needs maintenance in proper intervals,
- If cannot be operated for distant places,
- Power sources like battery are required.

3.5 Applications

- It can be used for the agricultural applications,
- spying copter etc

4. Conclusion

This project work has provided us an excellent opportunity and experience, to use our limited knowledge. We gained a lot of practical knowledge regarding, planning, purchasing, assembling and machining while doing this project work. We feel that the project work is a good solution to bridge the gates between the institution and the industries.

We are proud that we have completed the work with the limited time successfully. The unmanned aerial vehicle spraying fertilisers and pesticides on agriculture fields is working with satisfactory conditions. We can able to understand the difficulties in maintaining the tolerances and also the quality. We have done to our ability and skill making maximum use of available facilities.

In conclusion remarks of our project work, let us add a few more lines about our impression project work. Thus we have developed an “unmanned aerial vehicle spraying fertilisers and pesticides on agriculture fields” which helps to design a robot. In this project, we have combined the mechanisms of robotic and monitoring systems using an electronic control unit which actually moves and records the instants of the soil report and feeds it back to the control unit.

References

- [1] R. Daroya and M. Ramos, "NDVI image extraction of an agricultural land using an autonomous quadcopter with a filter-modified camera," *2017 7th IEEE International Conference on Control System, Computing and Engineering (ICCSCE)*, Penang, 2017, pp. 110-114.
- [2] Spoorthi S., B. Shadaksharappa, Suraj S. and V. K. Manasa, "Freyr drone: Pesticide/fertilizers spraying drone - an agricultural approach," *2017 2nd International Conference on Computing and Communications Technologies (ICCCT)*, Chennai, 2017, pp. 252-255.

- [3] F. G. Costa, J. Ueyama, T. Braun, G. Pessin, F. S. Osório and P. A. Vargas, "The use of unmanned aerial vehicles and wireless sensor network in agricultural applications," *2012 IEEE International Geoscience and Remote Sensing Symposium*, Munich, 2012, pp. 5045-5048.
- [4] Meivel, s & Maguteeswaran, R & Gandhiraj, N & Srinivasan, G. (2016). Quadcopter UAV Based Fertilizer and Pesticide Spraying System.
- [5] UM Rao Mogili, B B V L Deepak, "Review on Application of Drone Systems in Precision Agriculture," *Procedia Computer Science*, Volume 133, 2018, Pages 502-509.