

## SINGLE PHASE INDUCTION MOTOR DRIVE USING Z-SOURCE INVERTER

V.S.Neve\*

P.H.Zope

S.R.Suralkar

### **ABSTRACT**

*In this paper modelling and simulation of Z-source inverter fed single phase induction motor drive is presented. Traditionally Voltage Source Inverter (VSI) and Current Source Inverter (CSI) fed induction motor drives have a limited output voltage range. Conventional VSI and CSI support only current buck DC-AC power conversion and need a relatively complex modulator. The limitations of VSI and CSI are overcome by Z-source inverter. The Z-source inverter system employs a unique impedance network in the DC link and a small capacitor on the AC side of the diode front end. By controlling the shoot-through duty cycle, the Z-source can produce any desired output AC voltage, even greater than the line voltage (i.e. 325V for 230V AC) regardless of the input voltage.*

**Keywords:** *current source inverter (CSI), voltage source inverter (VSI), Z-source inverter (ZSI), Induction motor drives , PWM control , Buck-Boost.*

---

\* Dept. Of Electronics & Telecommunication , SSBT'S Jalgaon , India

## 1.Introduction

There exist two traditional converters: voltage-source converter(VSI) and current-source converters(CSI).Fig.1 shows the traditional single-phase voltage-source converter (abbreviated as V-source converter) structure. A dc voltage source supported by a relatively large capacitor feeds the main converter circuit, to a single-phase circuit. The dc voltage source can be a battery, fuel-cell stack, diode rectifier, and/or capacitor. Four switches are used in the main circuit; each is traditionally composed of a power transistor and an anti parallel (or freewheeling) diode to provide bidirectional current flow and unidirectional voltage blocking capability. The V-source converter is widely used.

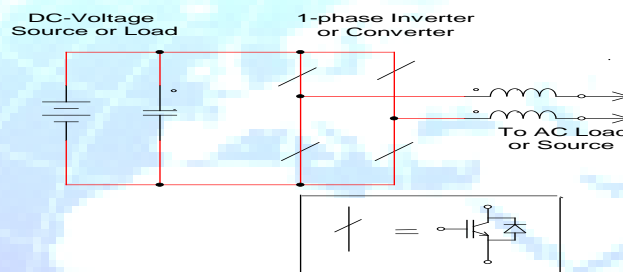

Fig.1 V-source converter

However, it has the following conceptual and theoretical barriers and limitations.

- The ac output voltage is limited below and cannot exceed the dc-rail voltage or the dc-rail voltage has to be greater than the ac input voltage. Therefore, the V-source inverter is a buck (step-down) inverter for dc-to-ac power conversion and the V-source converter is a boost (step-up) rectifier (or boost converter) for ac-to-dc power conversion. For applications where over drive is desirable and the available dc voltage is limited, an additional dc-dc boost converter is needed to obtain a desired ac output. The additional power converter stage increases system cost and lowers efficiency.
- The upper and lower devices of each leg cannot be gated on simultaneously either by purpose or by EMI noise. Otherwise, a shoot-through would occur and destroy the devices. The shoot-through problem by electromagnetic interference (EMI) noise's misgating-on is a major killer to

the converter's reliability. Dead time to block both upper and lower devices has to be provided in the V-source converter, which causes waveform distortion, etc.

- An output *LC* filter is needed for providing a sinusoidal voltage compared with the current-source inverter, which causes additional power loss and control complexity.

Fig. 2 shows the traditional single-phase current-source converter (abbreviated as I-source converter) structure. A dc current source feeds the main converter circuit, to a single-phase . The dc current source can be a relatively large dc inductor fed by a voltage source such as a battery, fuel-cell stack, diode rectifier, or thyristor converter. Four switches are used in the main circuit, each is traditionally composed of a semiconductor switching device with reverse block capability such as a gate-turn-off thyristor (GTO) and SCR or a power transistor with a series diode to provide unidirectional current flow and bidirectional voltage blocking.

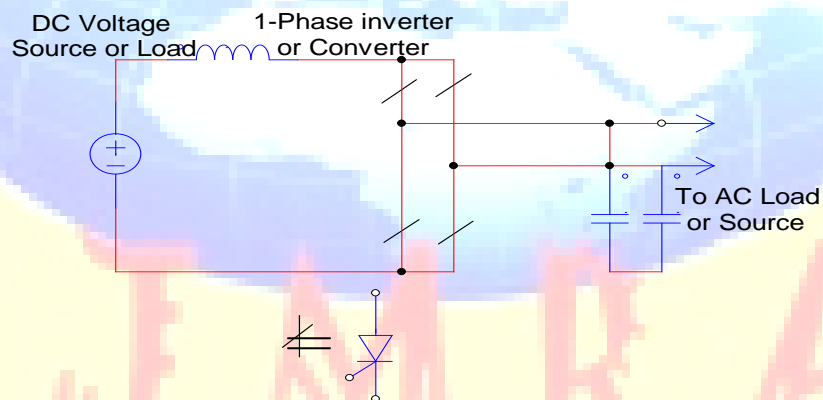

Fig.2 I-source converter

However, the I-source converter has the following conceptual and theoretical barriers and limitations.

- The ac output voltage has to be greater than the original dc voltage that feeds the dc inductor or the dc voltage produced is always smaller than the ac input voltage. Therefore, the I-source inverter is a boost inverter for dc-to-ac power conversion and the I-source converter is a buck rectifier (or buck converter) for ac-to-dc power conversion. For applications where a wide

voltage range is desirable, an additional dc–dc buck (or boost) converter is needed. The additional power conversion stage increases system cost and lowers efficiency.

- At least one of the upper devices and one of the lower devices have to be gated on and maintained on at any time. Otherwise, an open circuit of the dc inductor would occur and destroy the devices. The open-circuit problem by EMI noise's misgating-off is a major concern of the converter's reliability. Overlap time for safe current commutation is needed in the I-source converter, which also causes waveform distortion, etc.
- The main switches of the I-source converter have to block reverse voltage that requires a series diode to be used in combination with high-speed and high-performance transistors such as insulated gate bipolar transistors (IGBTs). This prevents the direct use of low-cost and high-performance IGBT modules and intelligent power modules (IPMs).

In addition, both the V-source converter and the I-source converter have the following common problems.

1. They are either a boost or a buck converter and cannot be a buck–boost converter. That is, their obtainable output voltage range is limited to either greater or smaller than the input voltage.
2. Their main circuits cannot be interchangeable. In other words, neither the V-source converter main circuit can be used for the I-source converter, nor vice versa.
3. They are vulnerable to EMI noise in terms of reliability.

## 2. Impedance Source Inverter

The Impedance Source Inverter is used to overcome the problems in the traditional source inverters. This impedance source inverter shown in Fig.3 employs a unique impedance network coupled with the inverter main circuit to the power source. This inverter has unique features compared with the traditional sources.

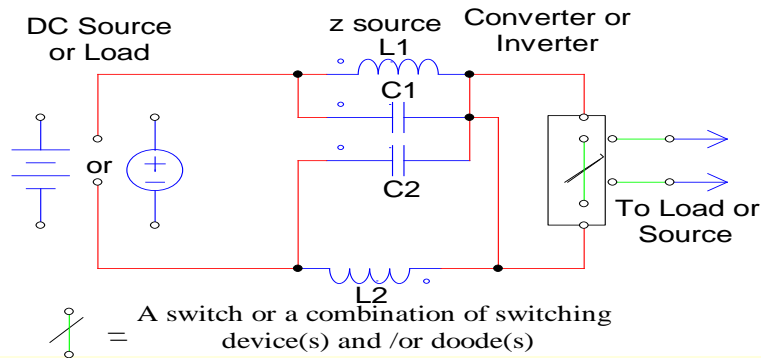

Fig.3 Z-source inverter

### 3. Impedance Network

Impedance network is a two port network. Usually one pair represents the input and other represents the output. This network also called as lattice network. Lattice network is the one of the common four terminal two port network. The lattice network is used in filter sections and is also used as attenuators. Lattice networks are sometimes used in preference to ladder structure in some special applications. This lattice network that consists of split inductors  $L1$  and  $L2$  and capacitors  $C1$  and  $C2$  connected in X-shape.

The equivalent circuit of the Impedance source inverter is shown in Fig.4 The impedance source network is a combination of two inductors and two capacitors. This combined circuit, the Impedance Source Network is the energy storage or filtering element for the Impedance Source inverter. This impedance source network provides a second order filter. This is more effective to suppress voltage and current ripples. The inductor and capacitor requirement should be smaller compared to traditional inverters.

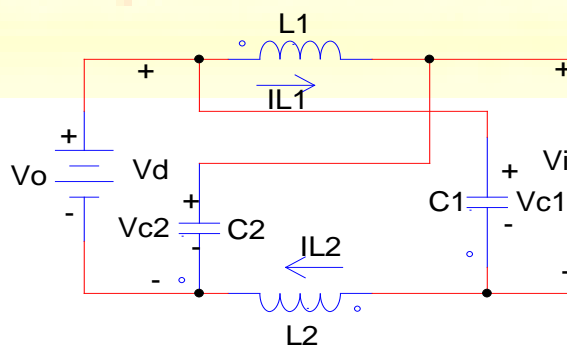

Fig.4 Equivalent circuit of the impedance source inverter.

When the two inductors (L1 and L2) are small and approach zero, the Impedance source network reduces to two capacitors (C1 and C2) in parallel and becomes traditional voltage source. Similarly, when the two capacitors (C1 and C2) are small and approach zero, the Impedance Source Network reduces to two inductors (L1 and L2) in series and becomes a traditional current source. Therefore considering additional filtering and energy storage by the capacitors, the impedance source network should require less inductance and smaller size compared with the traditional current source inverters.

#### 4. Mathematical Analysis Of Impedance Network

The impact of the phase leg shoot through on the inverter performance can be analyzed using the equivalent circuit shown in Fig.5 and Fig.6 Assume the inductors (L1 and L2) and capacitors (C1 and C2) have the same inductance and capacitance values respectively; the Z-source network becomes symmetrical.

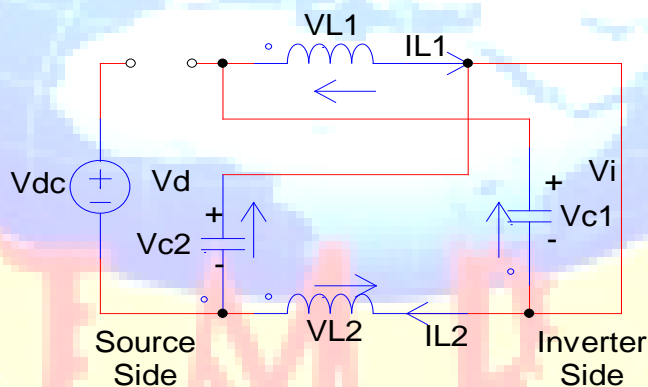

Fig.5 Equivalent circuit when zsi in shoot through state.

In shoot through state the inverter side of Z-Source network is shorted during time interval  $T_0$  as in Fig.5 Therefore  $L_1=L_2=L$  and  $C_1=C_2=C$ .

$$V_{c1} = V_{c2} = V_C = V_{L1} = V_{L2} = V_L$$

$$V_d = V_L + V_C = 2 V_C \tag{1}$$

$$V_i = 0$$

Alternatively, when in non shoot through active or null state current flows from Z-Source network through the inverter topology to connect ac load during time interval  $T_1$ . The inverter side of the Z-source network can now be represented by an equivalent circuit as shown in Fig.6. The following equations can be written:

$$V_L = V_{dc} - V_C$$

$$V_d = V_{dc}$$

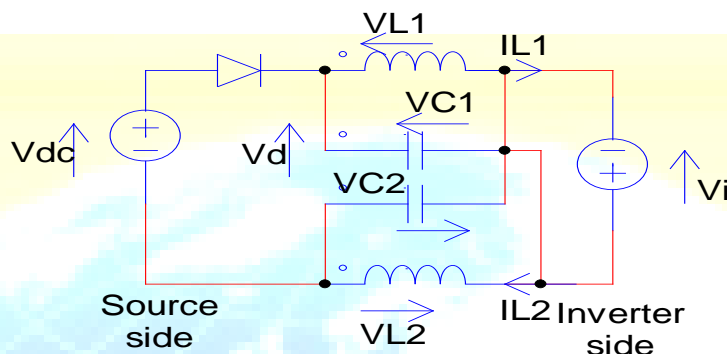

Fig.6 Equivalent circuit when zsi in non shoot through state.

$$V_i = V_c - V_L = 2 V_c - V_{dc} \quad (2)$$

Averaging the voltage across a Z-source inductor over a switching period (0 to T),

$$V_c = T_1 / (T_1 - T_0) V_{dc} \quad (3)$$

Using equations (2) and (3), The peak DC-link voltage across the inverter bridge is

$$V_i = 2 V_c - V_{dc} = 1 / (1 - 2T_0/T) V_{dc} \quad (4)$$

$$V_i = B \cdot V_{dc} \quad (5)$$

where,

$$B = T / (T_1 - T_0) \text{ i.e. } \geq 1$$

B is a boost factor, T-Switching period .

The peak ac output phase voltage, For Z- source

$$V_{ac} = M \cdot V_i / 2 = B \cdot M V_{dc} / 2$$

In the traditional sources

$$V_{ac} = M \cdot V_{dc} / 2$$

where M is modulation index.

The output voltage can be stepped up and down by choosing an appropriate buck–boost factor.

$$B.B. = B.M \text{ (it varies from 0 to } \alpha \text{)}$$

The Buck - Boost factor BB is determined by the modulation index M and the Boost factor B. The boost factor B can be controlled by duty cycle of the shoot through zero state over the non-shoot through states of the PWM inverter. The shoot through zero state does not affect PWM control of the inverter, because it equivalently produce the same zero voltage to the load terminal. The available shoot through period is limited by the zero state periods that are determined by the modulation index.

## 5. Simulation Result

Simulations have been performed to confirm the above analysis.

Fig.7 shows the circuit configuration of Z-Source fed induction motor drive .

The simulation parameters are as follows:

Input voltage : 110 Vrms

Switching frequency:10 kHz

Impedance network:  $L1=L2= 160\text{mH}$  ,  $C1=C2= 1000 \mu\text{F}$ .

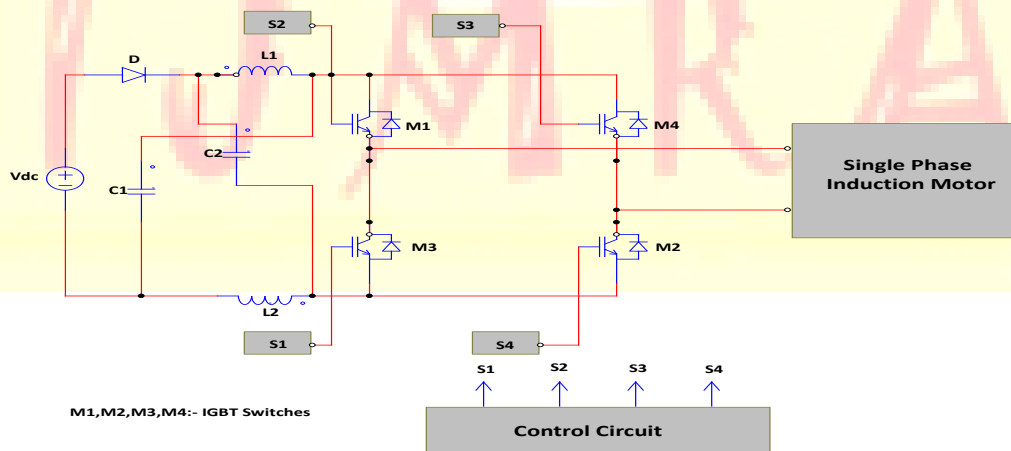

Fig.7 ZSI fed im drive



Fundamental voltage, current, and total harmonic distortion of z-source inverter varies with different modulation index.

Table 1: Variation of voltage and current with modulation index.

Sr. No.	M	V <sub>out</sub>	I <sub>out</sub>	Fundamental V <sub>L</sub>	%THD V <sub>L</sub>	Fundamental I <sub>L</sub>	%THD I <sub>L</sub>
1	0.6	170	200	175.9	8.73	213.3	19.15
2	0.75	246.6	265.4	229.6	8.01	280.6	22.89
3	0.8	286.1	312	254.3	9.47	311.2	27.39
4	0.85	322.1	338.3	280.5	10.10	343.1	30.10
5	0.95	422.7	459.4	334.3	13.21	405.4	40.96
6	1	504	586.8	371.6	14.77	450.6	45.77
7	1.02	579.9	675.7	371.6	14.77	450.6	45.77
8	1.05	585.4	738.6	402.7	16.12	488.7	49.76
9	1.10	670.3	867.8	428.5	17.36	520.4	53.42

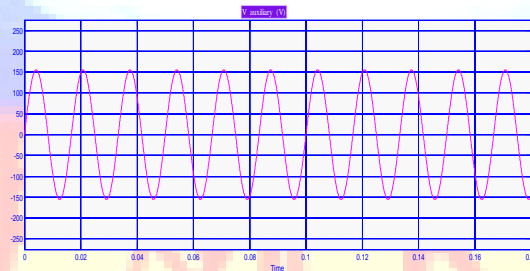

Fig.8 Input ac voltage

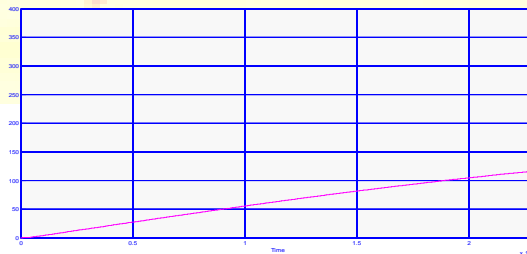

Fig.9 Rectifier output voltage waveform

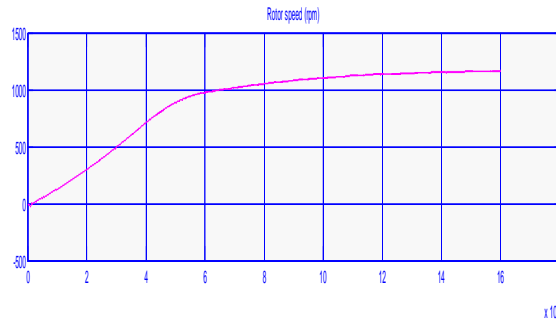

Fig.10 Rotor speed curve

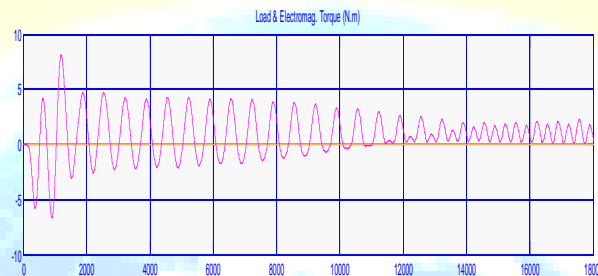

Fig.11 Load & electromag. torque

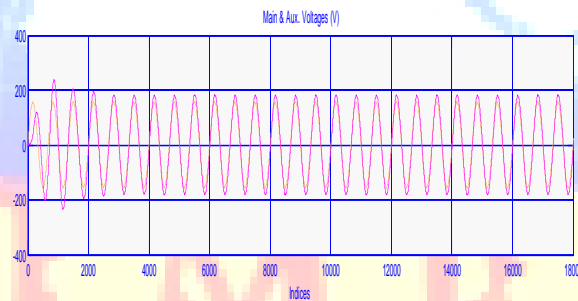

Fig.12 Main & aux. voltage

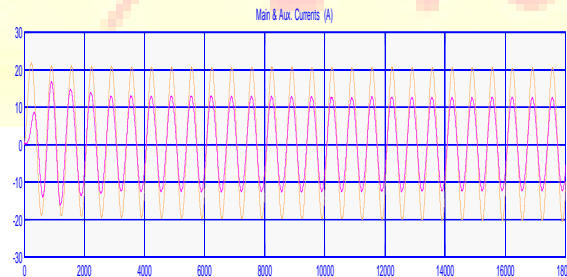

Fig.13 main & aux. current

## 6. Hardware Configuration

Fig.14 shows the prototype model of Z-source fed induction motor drive. The hardware parameters are as follows:

Input voltage: 12v

Z-source network:  $L_1 = L_2 = 160\text{mH}$  ,  $C_1 = C_2 = 1000\mu\text{F}$ .

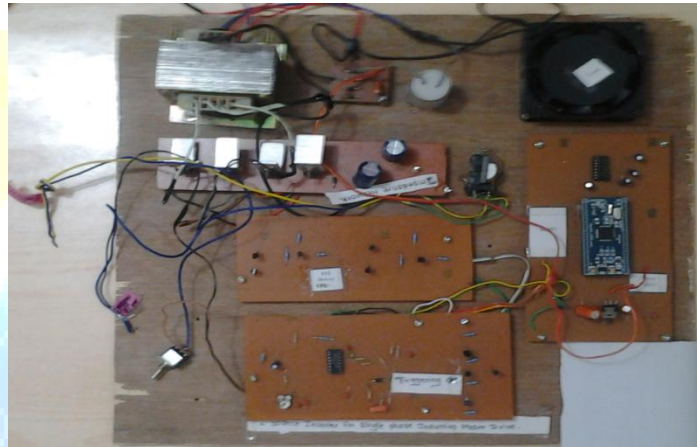

Fig.14 Hardware configuration

## 7. Conclusion

The simulation of Z-source inverter fed induction motor drive has been carried out. Analysis, simulation, and experimental results verified that the output voltage can be boosted to any value irrespective of input voltage by using Z-Source inverter.

## References

- [1] G. Pandian, S. Rama Reddy, “*Embedded Controlled Z Source Inverter Fed Induction Motor Drive*” *Journal of Applied Sciences Research*, 4(7): 826-832, 2008.
- [2] F.Gao, P.C.Loh, F.Blaabjerg and C.J.Gajanayake, “*Operational Analysis and Comparative Evaluation of Embedded Z-Source Inverters*” *IEEE xplore VOL 1, NO 1, 2757 -63 April 08*.
- [3] B. Justus Rabi and R. Arumugam, “*Harmonics Study and Comparison of Z-source Inverter with Traditional Inverters*”, in *American Journal of Applied Sciences* 2 (10): 1418-1426, 2005, ISSN 1546-9239 2005 Science Publications.
- [4] LOH P.C., VILATHGAMUWA D.M., LAI Y.S., CHUA G.T., LI Y.: ‘Pulse width modulation of Z-source inverters’, *IEEE Trans. Power Electron.*, 2005, 20, (6), pp. 1346–1355
- [5] PENG F.Z., JOSEPH A., WANG J., ET AL.: ‘Z-Source inverter for motor drives’, *IEEE Trans. Power Electron.*, 2005, 20, (4), pp. 857–863
- [6] Fang Zheng Peng and Yi Huang Michigan, “Z-Source Inverter for Power Conditioning and Utility Interface of Renewable Energy Sources,” *IEEE Trans* , Vol. 23, no. 4, 2004.
- [7] M. Shen, J.Wang, A. Joseph, F Z. Peng, L. M. Tolbert, and D. J. Adams, “Maximum constant boost control of the Z-source inverter,” presented at the *IEEE Industry Applications Soc. Annu. Meeting*, 2004.
- [8] F. Z. Peng, “Z-source inverter,” *IEEE Trans. Ind. Applicat.*, Vol. 39, no.2, pp.504–510, Mar./Apr. 2003.
- [9] CHOMAT M., LIPO T.A.: ‘Adjustable-speed single-phase IM drive with reduced number of switches’, *IEEE Trans. Ind. Appl.*, 2003, 39, (3), pp. 819–825
- [10] BA-THUNYA A.S., KHOPKAR R., WEI K., TOLIYAT H.A.: ‘Single phase induction motor drives-a literature survey’. *IEEE Int. Electric Machines and Drives Conf., IEMDC*, 2001, pp. 911–916
- [11] MULJADI E., ZHAO Y., LIU T., LIPO T.A.: ‘Adjustable ac capacitor for a single-phase induction motor’, *IEEE Trans. Ind. Appl.*, 1993, 29, (3), pp. 479–485
- [12] LETTENMAIER T.A., NOVOTNY D.W., LIPO T.A.: ‘Single phase induction motor with an electronically controlled capacitor’, *IEEE Trans. Ind. Appl.*, 1991, 27, (1), pp. 38–43
- [13] COLLINS E.R., PUTTGEN H.B., SAYLE W.E.: ‘Single-phase induction motor adjustable speed drive: direct phase angle control of the auxiliary winding supply’. *Proc. Industry Applications Society Annual Meeting*, 2– 7 October 1988, vol. 1, pp. 246–252